

Bio-gas:  
GP Option for  
Community Development

Prepared for  
Asian Productivity Organization

By  
Dr. Suporn Koottatep  
Mr. Manit Ompont  
Dr. Tay Joo Hwa

## **Bio-gas: GP Option for Community Development**

### **Content**

- 1. Green Productivity Concept and Practices, 1**
  - 2. An Overview of Green Productivity for Community Development, 16**
  - 3. Review of Bio-gas Technology, 37**
  - 4. Construction Manual of Bio-gas Reactor, 46**
  - 5. Steps of Bio-gas Reactor Construction, 55**
  - 6. Additional Information in Reactor Construction, 77**
  - 7. Operation Manual of Bio-gas Reactor, 97**
- Bibliography, 114**

## CHAPTER 1

### Green Productivity Concept and Practices

#### 1.1 Introduction

The increase in human need and the explosion of population within the last decade have resulted in severe environmental problems at present. During the last three decades, at least a seven-fold increase in manufacturing output has been estimated. By the middle of next century, an increase of ten folds will be expected. As a result many of the natural resources are depleting. Water resource is one of the major issues in many parts of the world. Scarcity of water and the deterioration of water quality from human use give rise to environmental problems throughout the world. Energy consumption has been increased rapidly through industrial development and increase of domestic demand. The wide spread use of chemicals such as pesticides and fertilizers in agriculture contaminates the environment and also threatens our eco-system. Greenhouse gases, such as carbon dioxides and methane, are produced from industries and burning of energy sources in rural area. Improper waste treatment also produces greenhouse gas through anaerobic process. This causes global warming. Up to early 1960, public awareness on environmental problems was rather low. The later half of the 1960s were a period that concerns on environmental issues became alive. Since 1970, responses and actions from many international agency and many individual countries were initiated to work more on the issues. The depletion in resources has become a major issue at present.

Green Productivity (GP) signifies a new paradigm of socio-economic development aimed at pursuing economic and productivity growth while protecting the environment. The concept of Green Productivity emerged in the early 1990s when people started to realize that emphasizing productivity and economic growth alone may lead to an adverse and irreversible effect on the environment. Solving environmental problems using end-of-pipe technology is not cost effective nor sustainable in the long run. There is a need for developing strategies which are simultaneously productivity enhancing and environmental friendly.

#### 1.2 Concept of Green Productivity

Green Productivity is a concept of harmonizing the socio-economic development and mechanism of environmental protection. It is the key for enhancing the quality of life of people through sustainable development. Improvement of quality of life is often associated with an increase in demand for goods and services. The increase in productivity will normally deplete natural resources and generate wastes which cause environmental damage. Conventional productivity improvement techniques have not paid due attention to environmental aspects. The environmental cost has been intentionally neglected in the system. Wastes have been counted as valueless. Excessive use of resources or generation of pollution is indicative of low productivity as well as poor environmental performance. GP pursues a strategy based on the technical and managerial interventions to improve the situation.

The definition of Green Productivity is:

***Green Productivity is a strategy for enhancing productivity and environmental performance of overall socio-economic development. It is the application of appropriate techniques, technologies and management systems to produce environmentally compatible goods and services.***

Green Productivity (GP) is applicable not only to the manufacturing sector, but also to the agriculture and services sectors. GP also addresses the interaction between economic activities and community development. Another dimension of GP is the role of the public sector (government and education) in environmental protection and awareness. GP is a stepwise approach and also a process of continuing improvement.

- The first step in this process is to identify ways to prevent pollution or waste at its source, as well as reduce the level of resource inputs by the process of rationalization and optimization. Possibilities of reuse, recovery and recycle are looked into to salvage the wastes generated.
- Next, opportunities for substituting toxic or hazardous substances are explored to reduce the life-cycle impact of the product. At this stage, the product itself is examined, including packaging in the framework of design for environment.
- Finally, the wastes in its residual forms are treated adequately to meet the regulatory requirements both from the perspectives of the workspace and the receiving environment. In order to ensure a continuous improvement in the productivity as well as in the level of environmental protection, a management system is developed, much on the lines of Environmental Management System of ISO 14000 series.

### **1.3 Green Productivity Tool and Techniques**

The basic concept of GP is built around the prevention of wastes and emissions at the point of generation. What cannot be prevented needs to be treated and thus rendered environmentally benign before discharging it to the recipient environmental media. This applies to both materials as well as energy wastes. GP techniques are classified into four categories – waste prevention, energy conservation, pollution control and design of product.

#### **1.3.1 Waste Prevention Techniques**

Waste prevention techniques can be applied to any manufacturing process, agricultural and service sectors. Available techniques range from easy operational changes to state-of-the-art recovery equipment. Waste prevention techniques can be broken down into five major categories: good housekeeping, inventory management, production process modification, volume reduction and recovery. In actual application, waste prevention techniques generally are used in combination so as to achieve maximum effect at the lowest cost. It has been experienced that a careful application of these techniques and a sincere commitment for implementation can lead to reduction in waste generation from 30% to 50% in most cases.

**a. Good Housekeeping**

Good housekeeping is not limited to keeping the work place clean and eliminating leakages and spillages. It also includes the operational practices involved, especially manual practices and making them more resource efficient. Preparation of recipes in right quantity to avoid surplus, efficient handling of materials, optimum storage procedures to avoid losses and material degradation during storage are illustrative examples of good housekeeping. It has been the experience that in small scale industries, good housekeeping alone could lead to a reduction in waste generation up to 20-25%.

**b. Inventory Management**

Proper control over raw materials, intermediate products, final products, and the associated waste streams is now being recognized by the industry as an important waste reduction technique. In many cases waste is just out-of-date, off-specification, contaminated, or unnecessary raw material, spill residues, or damaged final products. The cost of disposing of these materials not only includes the actual disposal costs but also the cost of the lost raw materials or products.

There are two basic aspects to inventory management, inventory control and material control.

**(i) Inventory Control**

Methods for controlling inventory range from a simple change in ordering procedures to the implementation of just-in-time (JIT) manufacturing techniques. Most of these techniques are well known in the business community. Many companies can help reduce their waste generation by tightening up and expanding current inventory-control programs. This approach will significantly impact the three major sources of waste resulting from improper inventory control: excess, out-of-date, and no-longer-used raw materials. Purchasing only the amount of raw material needed for a production run or a set period of time is one of the keys to proper inventory control.

If surplus inventories do accumulate, steps should first be taken to use the excess material within the plant or company. If this is not successful, then the supplier should be approached to see if it will take the material back. If the supplier won't, the next step is to identify possible users or markets outside the company. Only if this fails should other management options be examined.

**(ii) Material Control**

Proper material control procedures will ensure that raw materials will reach the production process without loss through spills, leaks, or contamination. It will also ensure that the material is efficiently handled and used in the production process and does not become waste. Material loss can be greatly reduced through improved process operation, increased maintenance, and additional employee training. Many sources of material loss, such as leaks and spills, can be easily identified and corrected.

### **c. Production Process Modification**

Improving the efficiency of a production process can significantly reduce waste generation. Using this approach can help reduce waste at the source of generation, thus decreasing waste management liability and costs. Available techniques range from eliminating leaks from process equipment to installing state-of-the-art production equipment.

#### **(i) Operational and Maintenance Procedures**

Significant amounts of waste can be reduced through improvements in the way a production process is operated and maintained. Improvements in operation and maintenance usually are relatively simple and cost-effective. Most of the techniques are not new or unknown.

*Operational procedures.* A wide range of methods are available to operate a production process at peak efficiency. Improved operation procedures optimize the use of raw materials in the production process. Most production processes, no matter how long they have been in operation or how well they are running, can be operated more efficiently. Some process steps may in fact be unnecessary, and eliminating them will reduce waste generation. Once proper operating procedures have been established they must be fully documented and be part of the employee training program. A comprehensive training program is a key element of any effective waste reduction program.

*Maintenance program.* About one-fourth to one-half of the excess waste load is due to poor maintenance. A strict maintenance program which stresses corrective and preventive maintenance can reduce waste generation caused by equipment failure. Such a program can help spot potential sources of waste and correct a problem before any material is lost.

#### **(ii) Material Change**

The manufacturing sector usually use the most cost benefit input raw materials in the production process without considering environmental aspects. Thus, highly toxic and hazardous chemicals came into use. Hazardous material used in either a product formulation or in a production process may be replaced with a less hazardous or non-hazardous material. Reformulating a product to contain less hazardous material should reduce the amount of hazardous waste generated during both the product's formulation and its end use. Using a less hazardous material in a production process will generally reduce the amount of hazardous waste produced.

#### **(iii) Process Equipment Modification**

Waste generation may be reduced by installing more efficient process equipment or modifying existing equipment to take advantage of better production techniques. New or updated equipment can use process materials more efficiently, producing less waste. Higher-efficiency systems may also reduce the number of rejected or off-specification products, thereby reducing the amount of material which has to be reworked or disposed of.

Modifying existing process equipment can be a very cost-effective method for reducing waste generation. In many cases, the modifications can just be relatively simple and inexpensive changes in the way the materials are handled within the process to ensure that they are not

wasted or lost. Process modifications and improved operational procedures can be used together to reduce waste.

#### **d. Volume Reduction**

Volume reduction includes techniques to separate hazardous wastes and recoverable wastes from the total waste stream. These techniques are usually used to increase recoverability, reduce the volume and thus the disposal costs, or increase management options. These techniques can be divided into two general areas, source segregation and waste concentration.

##### **(i) Source Segregation**

Segregation of wastes is a simple and economical technique for waste reduction. By segregating wastes at the source of generation and handling the hazardous and non-hazardous wastes separately, waste volume and thus management costs can be reduced. The uncontaminated or undiluted wastes may be reusable in the production process or may be sent off site for recovery. The segregation technique is applicable to a wide variety of waste streams and industries and usually involves simple changes in operational procedures.

##### **(ii) Concentration**

Various techniques are available to reduce the volume of a waste through physical treatment. Such techniques usually remove a portion of a waste, such as water. Concentration techniques are commonly used to dewater wastewater treatment sludges and reduce the volume by as much as 90 percent. Unless a material can be recycled, just concentrating a waste so that more waste can fit into a drum is not waste reduction. In some cases, concentration of a waste stream may also increase the likelihood that the material can be reused or recycled.

#### **e. Recovery**

Recovering wastes can provide a very cost-effective waste management alternative. This technique can help eliminate waste disposal costs, reduce raw material costs, and possibly provide income from a salable waste. Recovery of wastes is a widely used practice in many manufacturing processes and can be done on site or at an off-site facility.

##### **(i) On-Site Recovery**

The best place to recover process wastes is within the production facility. Waste can be most efficiently recovered at the point of generation, because the possibility of contamination with other waste materials is reduced. Other waste streams can be reused directly in the original production process as raw material. Some waste may have to undergo certain type of purification before it can be reused. A number of physical and chemical techniques available on the market can be used to reclaim the waste material. These techniques range from simple filtration to state-of-the-art techniques such as distillation. The method of choice will depend on the physical and chemical characteristics of the waste stream recovery economics, as well as on operational requirements.

Most on-site recovery systems will generate some type of residue. This residue can either be processed for further recovery or properly disposed of.

**(ii) Off-Site Recovery**

Wastes may be recovered at an off-site facility when (1) the equipment is not available to recover on site, (2) not enough waste is generated to make an in-plant system cost-effective, or (3) the recovered material cannot be reused in the production process. Off-site recovery usually entails recovering a valuable portion of the waste through chemical or physical processes or directly using the waste as a substitute for virgin material. Wastes directly used are usually chemically or physically specific for a selected purpose, and can range from concentrated acids to chemical by-product streams.

The cost of off-site recycling will depend on the purity of the waste and the market for the waste or recovered material. Some materials may be salable, while others may require a fee to be paid for disposal. The markets for some wastes are very volatile, and a waste material which has a value one day may have none the next.

**1.3.2 Energy Conservation Techniques**

Production facilities consume energy basically in two different forms: electricity and process heat. Combustion of fossil fuels in primary heat sources such as boilers or fired heaters provides a major source of heat input to industrial processes. Nearly all energy used in most manufacturing facilities is generated by processes that consume materials and generate pollutants (gaseous, liquid and solid) which pollute the environment if released directly. Any action that conserves energy would reduce the quantity of pollutants from energy-generating processes. On the other hand, actions that reduce pollutants would lower the expenditure of waste handling and treatment.

Combustion of fossil fuels in primary heat sources such as boilers or heaters provides a major source of heat input to industrial processes. Thermal energy can be conserved by taking care to prevent its loss during transport from the combustion site to the specific processes where it is used. Table 1.1 lists some measures that can be taken to conserve thermal energy as it is transported and used. It may also be possible to recover and use heat generated by production processes. Production facilities consume enormous amounts of electricity in both their production processes and the operation of their facilities. Table 1.1 lists several ways to conserve electricity.

Table 1.1. Example Approaches That Conserve Thermal and Electrical Energy

Thermal Energy Conservation	Electrical Energy Conservation
<ul style="list-style-type: none"> <li>• Adjust burners for optimal air/fuel ratio.</li> <li>• Improve or increase insulation on heating or cooling lines.</li> <li>• Institute regular maintenance to reduce leakage and stop steam trap bypass.</li> <li>• Improve the thermodynamic efficiency of the process using options such as:</li> </ul>	<ul style="list-style-type: none"> <li>• Implement housekeeping measures such as turning off equipment and lights when not in use.</li> <li>• Place cool air intakes and air-conditioning units in cool, shaded locations.</li> <li>• Use more efficient heating and refrigeration units.</li> </ul>



<ul style="list-style-type: none"> <li>* Using condensers or regenerative heat exchangers to recapture heat</li> <li>* Using heat pumps or similar equipment to recover heat at distillation column</li> <li>* Using more efficient heat exchangers</li> <li>• Co-generating heat and electricity.</li> </ul>	<ul style="list-style-type: none"> <li>• Eliminate leaks in compressed air supply lines.</li> <li>• Use more efficient motors.</li> <li>• Improve lubrication practices for motor driven equipment</li> <li>• Use efficient power transfer belts.</li> <li>• Use fluorescent lights and low wattage lamps or ballast.</li> <li>• Install timers and thermostats to better control heating and cooling.</li> </ul>
---	---

Source: USEPA 1992

### 1.3.3 End-of-pipe Treatment Technology

Whether waste is land disposed, emitted into the air or discharged to surface waters, all waste generators can strive to reduce waste generation to the point where treatment and subsequent disposal in the environment is avoided. However, for some processes, waste generation is inevitable. These wastes which cannot be eliminated, reduced, recycled or reused must be treated and disposed of within all applicable environmental regulations. Appropriate treatment does not include the transfer pollutants to other environmental media, or dilution as a means for meeting environmental regulations.

### 1.3.4 Designing Environmental Compatible Product

Environmentally compatible products minimize the adverse effects on the environment resulting from their manufacture, use, and disposal. The environmental impact of a product is to a large extent determined during its design phase. By taking environmental considerations into account during product planning, design, and development, a company can minimize the negative impact of its products on the environment.

Design changes made to prevent pollution should be implemented in such a manner that the quality or function of the product is not affected adversely. Design for the environment can be achieved by the people directly involved, within the framework of company policy and with support from company management, whether or not in response to incentive external to the company.

*Product Conservation.* Product conservation refers to the way in which an end product is used. For example, better maintenance of process equipment and components by industry can decrease the frequency of equipment component replacement, which in turn reduces the waste generated by the used component.

*Product Design Changes.* Product design changes involve manufacturing a product with a lower composition of hazardous substances, or less toxic materials being formed, or changing the composition so that no hazardous substances are involved

The goals of new product design can be reformulation and a rearrangement of product requirements to incorporate environmental considerations. For example, the new product can be made out of renewable resources, have an energy-efficient manufacturing process, have a

long life, be non-toxic, and be easy to reuse or recycle. In the design of a new product, these environmental considerations can become an integral part of the program of requirements.

#### 1.4 Green Productivity Methodology

For an effective Green Productivity Program, it is important to bring all stake holders together to ensure identification and implementation of maximum opportunities. A step by step procedure ensures exploitation of maximum Green Productivity opportunities. A typical Green Productivity Assessment Methodology is described as follows:

The methodology consists of 13 tasks divided into 6 steps. The main steps are:

<i>Step I</i>	<i>Get started</i>
<i>Step II</i>	<i>Planning</i>
<i>Step III</i>	<i>Generation and evaluation of GP options</i>
<i>Step IV</i>	<i>Implementation of Options</i>
<i>Step V</i>	<i>Monitoring and Review</i>
<i>Step VI</i>	<i>Sustaining Green Productivity</i>

Figure 1.1 shows the flow chart of GP methodology.

##### **Step I Get Started**

This step consists of the following 2 tasks, namely team formation and walk through survey.

##### ***Task 1 - Green Productivity Team Formation***

The first task in a Green Productivity program is to form a GP team. The GP team would coordinate the entire program, be responsible for identification of various GP measures, get them implemented and bear the overall responsibility. The GP team should be made up of representatives of group that will have interest in the results of the program. To the extent as possible, all the stakeholders should be represented in the team. The composition of the team would ultimately depend on the organizational structure and the requirements of the program. Inclusion of external experts helps in creativity and looking at the possible opportunities from a different perspective. The GP team should be capable of identifying potential areas, developing solutions and facilitating their implementation. For continuity and sustainability of the GP program, an in-house team is more desirable than a fully external team.

##### ***Task 2 - Walk through Survey and Information Collection***

GP team should familiarize itself with the manufacturing process including utilities, waste treatment and disposal facilities. A walk through survey would allow the team to identify and list all process steps. *Process diagram*, initial layout (*for eco-mapping*), drainage system, vents and other material/energy loss area should be prepared and identified. Special attention must be paid to periodic and intermittent waste generating steps as these often tend to be overlooked. House keeping practices should be observed and take note of obvious lapses. The GP team should prepare a preliminary list of waste generating operations, including a gross estimation of waste generate from different process steps. The possibility of waste prevention and control should be noted. Special attention should be paid to steps that generate toxic and

hazardous wastes. If a facilitator, who is not familiar with the operations of the organization, is involved in the GP exercise, the facilitator should gather general information about the organization. such as the number of employees in the organization and physical size of the factory or farm.

The above 2 tasks would help in selecting the first focus area for Green Productivity. Normally in larger premises, it would be desirable to focus on a smaller area so that the assessment can be completed fast and the results can also be shown at an early date. This help in generating and sustaining interest in the organization. Too wide a focus complicates the assessment and is time consuming.

Following the walk through survey, the team would have to gather detailed information of the organization. Information necessary for further evaluation such as detail process, flowchart, physical plant information, management structure, cost of purchasing raw materials, amount of raw materials purchased including energy use, should be gathering from concerned departments/sections. Detailed flow chart need to be prepared for further investigation and material balance step.

Technical information needed for further evaluation such as water use, waste generated, energy use, raw material use including existing waste treatment facilities should be collected. In case where no information is available in the plant, a practical survey and measurement should be performed to obtain the data. All the inputs and outputs of waste stream and emission should be identified and quantified. Special care needs to be taken of the recycle streams. Free and low cost inputs like water and air should be highlighted as these often tend to be neglected in production cost accounting but end up being the major source and cause of waste. Existing waste treatment facilities should be evaluated whether they conformed to legislative discharge limits and are operated within the designed condition. The periodic/batch/intermittent steps should be carefully highlighted. The GP team should also specify the items that do not appear in the usual input/output streams such as catalysts and coolant oil.

*Material/Energy balance* is important for any GP assessment since it enables identification and quantification of wastes and emissions. It provides information for ascertaining the cost of waste streams and thereby helps in monetary quantification of the loss. The balance also serves as a baseline data for evaluating the GP options and monitoring/comparing the advances made in the course of implementation of a GP program. Typical components of a material balance are given below.

<b>Input</b>	<b>Output</b>
Raw materials	Products
Catalyst	Gaseous emissions
Water	By-products including wastes for recovery
Air	Waste water and other liquid waste
Recycled materials	Solid waste for storage and/or disposal

Typical components of the energy balance are given below.

<b>Input</b>	<b>Output</b>
Electrical energy	Radiation loss
Steam	Energy in vapors and gases
Energy in raw materials	Energy in hot products
Condensation	Energy in hot residue
Cooling water	Energy in cooling water

Several factors should be considered while constructing the material/energy balance. The precision of data and flow measurement is essential. Time span is also important. Material balance constructed over too long a time period does not show the short term variations. On the other hand, material balance made over shorter time span requires repetitive and more accurate monitoring data to make the balance representative. Consistency of measurement units is another factor that needs to be taken care of. Making an energy balance is tougher than a material balance due to the fact that it requires more complex measurement systems and also because of its invisible nature.

## **Step II      Planning**

### ***Task 3 - Identification of Problems and Their Causes***

Problems concerning process efficiency, waste generation, energy loss should be identified and characterized at this step. Process inefficiency should be determined in order to be improved (if any) for higher productivity. The problems in materials and energy loss could be identified through material/energy balance. The waste streams could be in all 3 media i.e. solid, liquid and gaseous. It is now important to characterize these streams in terms of their constituents. To the extent possible, generic characterization such as BOD for organic pollution load should be avoided, as it does not throw open the possibilities of reduction and recycle. Characterization in terms of actual constituents is always more useful. It would also be a good idea to assign some sort of priority to the waste streams in terms of quantity, toxicity, possibility of recovery/recycle etc. Energy balance should reflect the areas where energy loss takes places. Only energy loss areas which are discrete, measurable and workable need to be identified e.g. energy loss due to friction between bearing and shaft need not be worked upon as it is not possible to recover and reuse this energy. Typical energy loss areas are heat loss in solid/liquid/gaseous streams, electrical energy loss due to under loading, excessive lighting and heat loss by radiation.

The cause analysis of problems identified can now be carried out. This analysis involves locating and pinpointing the causes of waste generation and energy loss. There could be a wide range of causes for waste generation and energy loss ranging from simple lapses in housekeeping to complex technological reasons. Quite often, each identified problem would have more than one cause and similarly the same cause might be applicable to more than one problem. The generic causes such as poor process control, improper design etc. should be avoided, as it does not lead to specific GP option development. Cause analysis should be specific and to the point. The use of the *Cause and Effect (Fishbone) diagram* would assist in identifying root cause of problems. Here, problems can often be traced to 5 main categories of causes, namely, Man, Machine, Material, Method and Environment. Holding

*brainstorming* sessions often leads to excellent cause analysis. The brainstorming should not be limited to people belonging to the area of concern as the causes could have been extended beyond these areas. The principles of good brainstorming should be followed.

#### ***Task 4 – Set Objectives and Targets***

Once the concerns are identified and prioritized, it is necessary to set objectives and targets. Objectives should be based on concerns identified. One objective can have multiple targets, which could be phased over time. Targets should be developed based on the need. For example, if legal compliance is to be sought within one year, then the target for an objective which addresses a compliance parameter should be set for one year.

Targets should be decided with an anticipatory perspective. For example, if a certain objective is to be sought within 2 years, it should be investigated whether the objective will be completely achieved in that time frame. It is possible sometimes that the value of concerns also might have changed in the 2 years, which would necessitate setting of another target in the future.

Step II should end in a list of identified problems and their causes in the selected focus area and objectives and targets which the organization will be working towards.

### **Step III      Generation and Evaluation of GP Options**

This is the most creative step in the entire GP assessment process. The efforts put in so far would now be made use of for determining problems solving options. The step consists of 3 tasks namely, development of GP options, preliminary screening and evaluation of options, and formulation of an implementation plan for the selected options.

#### ***Task 5 – Generation of GP Options***

The most significant task in entire GP methodology relates to the development of GP options. These options emerge directly from the cause analysis carried out earlier. This is the most creative phase of the GP Assessment Process as the GP team ready with data should now look for possible methods of reducing waste. Finding waste prevention options depends on the knowledge and creativity of its members, their education, work experience and facilitating resources. Resources such as personnel from the same or similar plant elsewhere, trade associations, success cases tried elsewhere, specialist organizations including R & D institutions, equipment suppliers and consultants could be sought. The process of finding waste prevention options should take place in an environment which stimulates creativity and independent thinking. Use of techniques like brain storming and group discussions are very helpful in generating and better ideas. Members of the GP team may also source information on the internet, books or other published literature.

#### ***Task 6 - Preliminary Screening of Options***

Under the earlier task, a list is prepared for all possible GP options that emerge in the brain storming or group discussion system. The first shifting of the workable options is now available. The options are distributed under 3 categories namely “option, which are directly implemented”, “options requiring further analysis” and “rejected options”. This

categorization should be done based on very simple and quick assessment. In case of any doubt, the option should be put into the middle category. The weeding out process should be simple, fast and straightforward and may often be only qualitative.

The options, which are placed in the first category of directly implemented options, should be taken up for implementation immediately. Options falling into the third category would be shelved for the time being. The remaining options falling into the second category would now be subjected to a more detailed feasibility analysis.

*a. Assessment of technical feasibility*

The technical evaluation determines whether the proposed option is technically workable under the given conditions. A typical checklist for technical evaluation should consist of

- Availability of hardware/technology
- Availability of operating skills
- Availability of space
- Effect on production
- Effect on product quality
- Safety aspects
- Maintenance requirements
- Effect on operational flexibility
- Shut down requirements for implementation

*b. Assessment of economic viability*

Economic viability is often the key parameter for promoting of discussing implementation of waste prevention options. For a smooth take off and for sustaining interest in the entire GP program, it is essential that the first few options should be economically very attractive. Such a strategy generates more interest and commitment. Options requiring small investment but involving more procedural changes like housekeeping measures, operational improvements, and process control measures, do not require intensive economic analysis and simple methods like 'pay back period' could be used. However, as the measures become more involved and capital intensive, methods like *internal rate of return (IRR)* or *Net Present Value (NPV)* need to be adopted to get a complete picture. While doing the economic assessment, the "cost" may include fixed capital cost i.e., cost of the hardware, shutdown cost and O&M cost. The "savings" may consist of savings of input material/energy, profit due to higher production levels, lower O&M cost, value of by-products, reduction in environmental cost such as waste treatment, transportation and disposal cost.

*c. Evaluation of environmental aspects*

The waste prevention options need to be analyzed with respect to their impacts on the environment. In many cases, the environment benefit is obvious - reduction in toxicity and/or quantity of waste. The other impacts be improved treatability of waste, changes in applicability of environmental regulations and applicability of simple End-of Pipe pollution control systems.

Initially the environmental aspects may not appear to be as important as technical and economical aspects. However, with increasing pressures from different customers, it is expected that, in due course, environmental evaluation may well become the most important criteria for selection of waste prevention solutions.

After technical, economic and environmental considerations, it is often difficult to decide which option should be taken up for implementation. A *rating matrix* helps in combining the results of three evaluations. Each aspect is given a weight as determined and agreed upon by the management. Each option is then assessed in the context of the given weight for each of the aspect. The sum of these marks would determine the ranking of options with regards to priority of implementation.

### ***Task 7 – Formulation of GP Implementation Plan***

The preparation for implementing waste prevention solutions requires arranging finances, technical preparation and establishing linkages with other departments. Support and cooperation of concerned persons has to be ensured. Checklists of tasks involved, agencies/departments to be approached provide good help. The implementation plan should cover a detailed activity plan, the inputs (including manpower and financial inputs), required time frame and the persons responsible for implementation. For implementation of any GP option, it is required to know the following :

Location / point of application of the option

Nature of the option

Resources necessary

Personnel necessary

Whether production or activity at or near the point of application of the option is to be stopped, altered or relocated.

Responsibility matrix and task allocation in teams

Details on cost requirements, when, how much sourcing of funds

Milestones to be set in the implementation sequence.

Step III should result in a prioritized list of GP options and its implementation plan.

### **Step IV                      Implementation of GP option**

#### ***Task 8 – Implementation of Selected Options***

The implementation of waste prevention solutions is similar to any other industrial modification. The task comprises preparation of drawings, ordering and procurement of equipment, transportation of the same to the site, installation and commissioning. Whenever required, simultaneous training of manpower should not be missed out as an excellent measure may fail miserably if not backed up by adequately trained people.

#### ***Task 9 – Training, Awareness Building and Develop Competence***

Depending on the nature of the GP options, the staff of the organizations will have to be trained for installation operation and maintenance of the GP option.

This step should result in a number of successfully implemented waste prevention solutions. Quite often, this step is the most time consuming step as the implementation is the single largest time consuming activity.

## **Step V            Monitoring and Review**

After implementation, it is important to continually monitor and evaluate the appropriateness of the options employed. The results have to be reviewed by the management.

### ***Task 10 - Monitoring and Evaluation of Results***

The performance of the options implemented should be monitored to compare the actual results with the expected ones. In case of any deviation, the cause needs to be determined and appropriate modifications, if required, should be carried out. The implementation job would be considered as completed only after sustained performance is recorded over a reasonable period of time.

### ***Task 11 – Management Review***

Post implementation review by management involves checking whether the overall GP program is proceeding in the right direction and whether targets are being achieved as per implementation plan.

## **Step VI            Sustaining Green Productivity**

The biggest challenge in Green Productivity lies in its sustainability, otherwise, the euphoria of the program dies out very soon and the situation returns to where it started. The zeal and tempo of the GP Team will also wane off backing out from commitment. Absence of rewards and appreciation for performers, shifting priorities are some of the commonly encountered reasons for such a project end of a Green Productivity program.

### ***Task 12 – Incorporate Changes into the Organization’s System of Management***

Green Productivity would not sustain in isolation. It should be integrated to become a part of day to day management practices. The GP team should establish a system for sustaining the implemented solutions, simultaneous development and implementation of ISO 14000 Environmental Management System would help in providing a structured system integrated with the basic management system.

### ***Task 13 - Identify and Select Next Focus Area***

The entire methodology can now be repeated for the second focus area. By the time one full cycle is completed, there would be fresh opportunities of waste prevention in the first focus area and the whole cycle could similarly be repeated. Green Productivity would, therefore, never end. It is a continuous process and would go on forever.



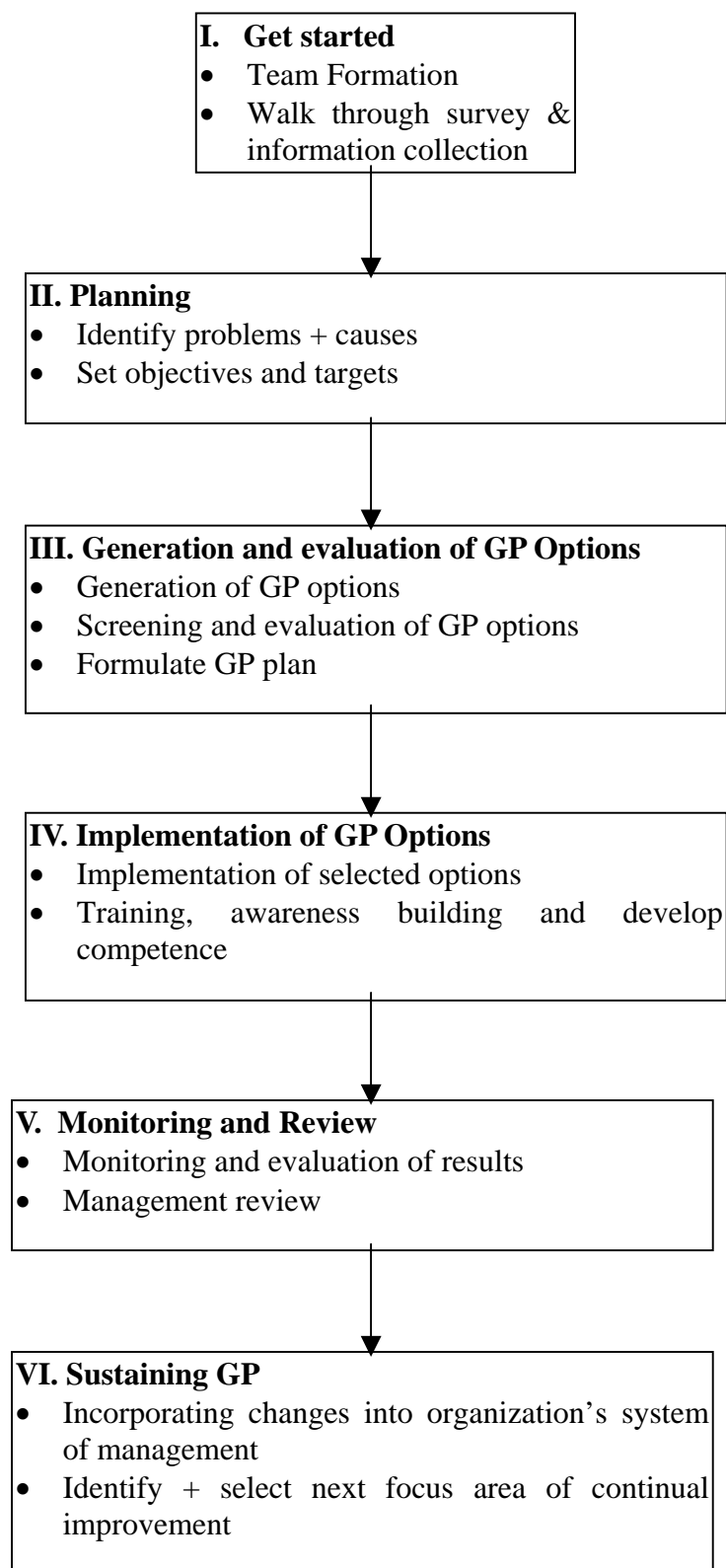

**Figure 1.1 Flow Chart of GP Methodology**

## CHAPTER 2

### An Overview of Green Productivity for Community Development

#### 2.1 Introduction

As mentioned in the previous chapter, GP is also applicable to non-industrial sectors. Community Development is one of the other sector which GP could be applied. At present, about 80% of the population in developing countries are living in rural area. In many developing countries, this group of people contributes to the major economic development of the countries. Agriculture, and small-scale agro-industry are the major activities in rural area. Apart from these income driven activities, other supporting activities such as small-scale animal farming, solid waste generation, farm residue and water supply are also major factors influencing the way of life of the people. The pressure of rapid population growth, and conventional farming methods are causing degradation of the environment and depletion of natural resources. Agricultural activities may produce wastes and generate hazardous residues in products and the environment. Farmers have been using all kinds of pesticides, herbicides, chemical fertilizers for total productivity enhancement without considering environmental and health impacts. Safe water supply and proper sanitation are not adequate in many developing countries. Human and animal waste creates health impacts in the rural area. Agricultural, water, forestry and environmental concerns have an impact on land use in rural communities.

In order to alleviate environmental problems, long term improvement of living conditions of the rural population should be planned. In many developing countries, the government has put a lot of efforts in assisting rural community development. The assistants are normally:

- To develop the ability of local officials to manage their own problems and find cost-effective solutions.
- To increase the visibility of rural community concerns in drinking water, wastewater and solid waste.
- To provide environmental education to rural public.
- To assist the communities in achieving compliance of their drinking water and wastewater systems

GP could be an useful strategy to improve living standard of the community.

#### 2.2 GP for Community Development

There are 5 important categories in community development especially in the rural area of developing countries.

*Increased use of the skills, knowledge and ability of local people:* Local people are the basis for community success. Ongoing improvements in skills and knowledge of a community's residents help build rural community progress.

*Strengthened relationships and communication:* Community efforts benefit when everyone has a voice, when all voices are encouraged and when residents understand the means to express their idea. Relationships with other communities and organizations are helpful for their own development.

*Improved community initiative, responsibility and adaptability.* A community that is responsible for its own future, makes change when conditions or assumptions change, monitors and documents the results of its action, learns from its experience, can become more resilient, more capable of adapting to change and can sustain itself over time.

*Sustainable, healthy ecosystems with multiple community benefits.* Human communities are part of natural ecosystems. They should plan and act in concert with nature.

*Appropriately diverse and healthy economies:* Vital economies deploy financial, natural and human resources to create, maintain and improve local livelihoods. In healthy economies, community residents move toward self-sufficient and prosperity.

Successful communities focus on outcome. Planning starts from where a community wants to go. Once that is clear (often in a vision or mission statement which states specific outcome), alternative ways of getting there can be considered (outputs). The actions (activities) necessary to achieve the various outputs can be considered. Finally, the inputs of time, skills, technical assistance, equipment, space and finance can be calculated. If the actions to get to an output that lead to an outcome are too costly, then another output that leads to the same outcome can be considered. This is a typical strategic planning activity, which builds on the Total Quality Management literature, which focuses on results.

GP could be a powerful strategy in community development.

### **2.3 GP Methodology in Community Development**

Green Productivity methodology for community development could be derived from the general GP methodology as shown in details in Chapter 1. There are 6 steps of GP methodology as follows:

<i>Step I</i>	<i>Get started</i>
<i>Step II</i>	<i>Planning</i>
<i>Step III</i>	<i>Generation and evaluation of GP options</i>
<i>Step IV</i>	<i>Implementation of Options</i>
<i>Step V</i>	<i>Monitoring and Review</i>
<i>Step VI</i>	<i>Sustaining Green Productivity</i>

#### **Step I Getting started**

This step consists of the following 2 tasks, namely team formation and walk through survey.

### ***Task 1 - Green Productivity Team Formation***

GP team in community development will be responsible for coordinating the entire GP program. The team needs to be responsible for the implementation of GP options generated from their activities. The GP team should be made up of representatives of group that will have interest in the results of the program. To the extent as possible, all the stakeholders should be represented in the team. GP team should comprise the following parties:

- Community leaders
- Local government officers
- Federal or Central government officers
- NGOs' representatives
- Academia
- Private sectors
- Consultants (if needed)

### ***Task 2 - Walk through Survey and Information Collection***

A walk through survey would allow the team to prepare themselves in understanding the real situation of the community. Information on environmental situation, physical infrastructure, socio-economic status of the communities should be collected for further analysis. The walk through survey could be performed using video camera, photograph and hand note. Problems in water supply, waste, agricultural condition, sanitation, and household industries should be studied.

Following the walk through survey, information concerning the community should be collected. Useful information in the community such as socio-economic information (Population, income, health, occupations etc) should be collected. Infrastructure and services such as water supply, waste management, and agriculture within the community should be studied. Detailed studies in infrastructure, which will be useful for GP are:

#### Water Supply

- Water sources, quantity and quality
- Water demand
- Water use in the community
- Problems

#### Waste

- Generation of waste in the community
- Management of waste in the community
- Problems generated from waste

#### Agriculture

- Types and kinds of agricultural products
- Amount of pest control and fertilizer used
- Problems generated from agricultural sector

The following questions should be answered during information collection:

What kind of water sources do the community use?

- Surface water
- Groundwater
- Rainwater
- How much water is available for community uses.

How is the water quality of water sources?

- Chemical analysis
- Physical analysis
- Biological analysis

Is the water suitable for consumption?

How much do the community need water for their consumption?

- At present
- In the future

Compare their demand to other places?

What kind of waste generated in the community?

- Wastewater
- Solid waste
- Air pollution

Amount of waste generated?

- Wastewater, m<sup>3</sup>/d, m<sup>3</sup>/year, m<sup>3</sup>/person-d
- Solid waste, m<sup>3</sup>/d, ton/d, gram/person-d
- Air pollution, smoke, dust etc.

Characteristic of waste?

- BOD, COD
- Toxicity
- Type

What kind of agricultural products, amount produce in the community?

- Rice
- Vegetables
- Fruits
- Animal husbandry

Consumption, locally or regionally?

Marketing potential?

What kinds and amount of pesticides are being used?

What kinds and amount of fertilizers are being used?

Are other alternatives available?

Compare to other areas?

These data will be the background information for further analysis.

## **Step II            Planning**

### ***Task 3 - Identification of Problems and Their Causes***

Problems concerning water supply, wastes generated, and agricultural activities should be identified. Problems to be identified depend mainly on the community standard of living, cultural background, and to a certain extent physical condition of the community. Similar situation from different communities may identify different problems. However, the consensus of the GP team should be important. A brain storming session among GP team should be organized to identify problems within the community. In order to identify problems many questions among the environmental activities need to be addressed. They are as follows:

- Do the community use too much water in their daily live?
- Are there enough water sources in the area?
- Do they have any alternatives in obtaining water from some where else?
- Does water quality suitable for consumption?
- Does water quality in natural sources suitable for recreation?
- Is water pollution a problem in the community?
- Do water treatment facilities suitable in treating water from the sources?
- Is there enough financial available for operation and maintenance?
- Is too much waste generated compare to other communities?
- Do they have proper waste management in the community?
- Do community have enough personnel, financial availability and appropriate technology within its reach?
- Do agricultural products meet consumption need?
- Did we use too much pesticide, herbicide, fertilizer etc?

There may be a lot more questions to be asked to understand the problems in the community. After a period of brainstorming, a number of problems will be identified. The next step is to group these problems into a common cause of problem. Later, cause analysis could be done. The cause analysis could be performed using Ishikawa diagram or Fish Bone diagram. This technique will lead the GP team to root causes of the problems.

### ***Task 4 – Set Objectives and Targets***

Once the problems are identified and prioritized, it is necessary to set objectives and targets to solve the concerned problem. One objective can have multiple targets, which could be phased over time. Targets should be developed based on the need of the community. For example, if water supply is the major issue, the improvement of water work should be done in one year. The information gathered during task 2 will be background information for setting proper objectives and targets to alleviate the community's problems.

Targets should be decided with an anticipatory perspective. For example, if a certain objective is to be sought within 2 years, it should be investigated whether the objective will

be completely achieved in that time frame. It is possible sometimes that the value of concerns also might have changed in the 2 years, which would necessitate setting of another target in the future.

Step II should end in a list of identified problems and their causes in the selected focus area and objectives and targets which the community will be working towards.

### **Step III      Generation and Evaluation of GP Options**

This is the most creative step in the entire GP assessment process. The efforts put in so far would now be made use of for determining problems solving options. The step consists of 3 tasks namely, development of GP options, preliminary screening and evaluation of options, and formulation of an implementation plan for the selected options.

#### ***Task 5 – Generation of GP Options***

The most significant task in the entire GP methodology relates to the development of GP options. These options emerge directly from the cause analysis carried out earlier. This is the most creative phase of the GP Assessment Process as the GP team should now look for possible methods of problems solving with the available data. In this task, a brainstorming session within the GP must be organized. The options should be generated within each sectors namely, water supply, wastewater, solid waste, air pollution, and agriculture sector. Water supply options could refer to options of alternative water sources, options in water treatment, and options in water preservation. Alternative of water sources could be from surface water such as stream, river, dam and reservoir or from ground water such as shallow well and deep well. Water treatment alternatives could be chemical, physical and biological treatment suitable for raw water sources. Water preservation could be done by public awareness campaign, reuse and recycle of wastewater. Options in waste management such as waste reduction, using waste as resources and wastewater treatment should be considered. Waste generation rate of either wastewater or solid waste could be reduced through campaigns, waste segregation, recycle and reuse. Alternatives in waste treatment and disposal such as pond system, constructed wetland, composting and bio-gas are very good options for community development. Options in agriculture practices such as alternative uses of chemical and bio-fertilizer, alternate crops, and bio-control should be considered.

Finding options depends on the knowledge and creativity of its members, their education, work experience and facilitating resources. Resources such as personnel from the same or similar situation elsewhere, success cases tried elsewhere, specialist organizations including R & D institutions, consultants etc could be sought. The process of finding options should take place in an environment which stimulates creativity and independent thinking. Use of techniques like brain storming and group discussions are very helpful in generating ideas. Members of the GP team may also source information on the internet, books or other published literatures.

#### ***Task 6 – Evaluation of GP Options***

The first step is to make a preliminary screening of the options generated. The options are classified into 3 categories. The first group of options, which do not require a high budget can be directly implemented. The second group of options, which may be too expensive or too

complicated, will be rejected. The third group of options which require a certain amount of financial support and are rather complicated should be further evaluated. In case of any doubt, an option should be put into the third category. The weeding out process should be simple, fast and straightforward and may often be only qualitative.

The options, which are placed in the first category of directly implemented options, should be taken up for implementation immediately. Options falling into the second category would be shelved for the time being. The remaining options falling into the third category would now be subjected to a more detailed feasibility analysis.

**a.     *Assessment of technical feasibility***

The technical evaluation determines whether the proposed option is technically workable under the given conditions. A typical checklist for technical evaluation should consist of

- Availability of hardware/technology
- Availability of operating skills
- Availability of space
- Safety aspects
- Maintenance requirements
- Effect on operational flexibility
- Availability of training resources

**b.     *Assessment of economic viability***

Economic viability is often the key parameter for promoting and discussing implementation of GP options. Unlike the industrial sector, the most important part will be the affordability by the community, and the possibility of obtaining financial budget elsewhere. For a smooth take off and for sustaining interest in the entire GP program, it is essential that the first few options should be economically very attractive. Such a strategy generates more interest and commitment. Options requiring small investment but involving more procedural changes like recycle of household waste, segregation of waste, do not require intensive economic analysis and simple methods like '*pay back period*' could be used. However, as the measures become more involved and capital intensive, methods like *internal rate of return (IRR)* or *Net Present Value (NPV)* need to be adopted to get a complete picture. While doing the economic assessment, the "cost" may include fixed capital cost i.e., cost of the hardware and O&M cost. The "savings" may consist of savings of input material/energy, lower O&M cost, value of by-products, reduction in environmental cost i.e., waste treatment, transportation and disposal cost.

**c.     *Evaluation of environmental aspects***

The GP options need to be analyzed with respect to their impacts on the environment. In many cases, the environment benefit is obvious - reduction in toxicity and/or quantity of waste. The other impacts are improved treatability of waste, changes in applicability of environmental regulations, improving environmental situation in the community, reduce odor and improving of aesthetic environment etc.



After technical, economic and environmental considerations, it is often difficult to decide which option should be taken up for implementation. A *rating matrix* helps in combining the results of three evaluations. Each aspect is given a weight as determined and agreed upon by the management. Each option is then assessed in the context of the given weight for each of the aspect. The sum of these marks would determine the ranking of options with regards to priority of implementation.

### ***Task 7 – Formulation of GP Implementation Plan***

The preparation for implementing GP solutions requires arranging finances, technical preparation and establishing linkages with other organizations. Support and cooperation of concerned persons has to ensured. Checklists of tasks involved, agencies/departments to be approached provide good help. The implementation plan should cover a detailed activity plan, the inputs (including manpower and financial inputs), required time frame and the persons responsible for implementation. For implementation of any GP option, it is required to know the following :

- Location / point of application of the option
- Nature of the option
- Resources necessary
- Personnel necessary
- Responsibility matrix and task allocation in teams
- Details on cost requirements, when, how much sourcing of funds
- Milestones to be set in the implementation sequence.

Step III should result in a prioritized list of GP options and its implementation plan.

### **Step IV      Implementation of GP option**

#### ***Task 8 – Implementation of Selected Options***

The implementation of GP solutions is similar to any other activities. The task comprises preparation of design and drawings, ordering and procurement of equipment, transportation of the equipment to the site, installation and commissioning. Training of manpower and all stakeholders should not be missed out as an excellent measure may fail miserably if not backed up and used by adequately trained people.

#### ***Task 9 – Training, Awareness Building and Develop Competence***

Depending on the nature of the GP options, the community need to be educated for all of the applications of the GP options.

This step should result in a number of successfully implemented GP solutions. Quite often, this step is the most time consuming step as training, campaigning are certainly time consuming activities. And it requires continuous program to sustain the activities.

## **Step V            Monitoring and Review**

After implementation, it is important to continually monitor and evaluate the appropriateness of the options employed. The results have to be reviewed by the GP team.

### ***Task 10 - Monitoring and Evaluation of Results***

The performance of the options implemented should be monitored to compare the actual results with the expected ones. In case of any deviation, the cause needs to be determined and appropriate modifications, if required, should be carried out. The implementation job would be considered as completed only after sustained performance is recorded over a reasonable period of time.

### ***Task 11 – Management Review***

Post implementation review by GP team involves checking whether the overall GP program is proceeding in the right direction and whether targets are being achieved as per implementation plan.

## **Step VI            Sustaining Green Productivity**

The biggest challenge in Green Productivity lies in its sustainability, otherwise, the euphoria of the program dies out very soon and the situation returns to where it started. The zeal and tempo of the GP Team will also wane off backing out from commitment. Absence of rewards and appreciation for performers, shifting priorities are some of the commonly encountered reasons for such a project end of a Green Productivity program.

### ***Task 12 - Incorporate Changes into the Community's System of Management***

Green Productivity would not sustain in isolation. It should be integrated to become a part of day to day way of living. The GP team should establish a system for sustaining the implemented solutions.

### ***Task 13 - Identify and Select Next Focus Area***

The entire methodology can now be repeated for the second focus area. By the time one full cycle is completed, there would be fresh opportunities of GP in the first focus area and the whole cycle could similarly be repeated. Green Productivity would, therefore, never end. It is a continuous process and would go on forever.

## **2.4    Experience of GP for Community Development in Vietnam**

*(Extracted from the Green Productivity Demonstration Project by VPC Vietnam)*

A demonstration program on GP in community development has been carried out in Vietnam during the period of June 1998-June 1999. This project is the Green Productivity Demonstration Program (GPDP) sponsored by APO and implemented by Vietnam Productivity Center (VPC).

The main objective of the GPDP project was to demonstrate the application of GP approach for the environmental problems within the integrated community since GP is an appropriate approach to reduce environmental degradation of the community.

GPDP project has established a GP application model and experiences gained would be disseminated to other communities. Three communities are selected for the GPDP project – two in the North and the other in the South. Tinh Loc and Kha Ly Ha communities are located 70 km from Hanoi in the North and My Khanh B is located 45 km from Ho Chi Minh city in the South.

### **2.4.1 Objectives**

The objectives of the program were to change the attitudes of villagers about environmental protection, and to create a new habit to live through sustainable development. The detailed objectives were as follows:

- a) To improve the quality of life through improving standard of living, decreasing poverty, improving health condition and improving kids' education.
- b) To improve agricultural productivity through Integrated Pest Management (IPM).
- c) To improve environmental condition through improvement of drinking water supply, wastewater facilities, solid waste management, human and animal wastes management.

### **2.4.2 Methodology**

The methodology of the project closely followed the Green Productivity (GP) methodology developed by APO. The methodology consists of 13 tasks divided into 6 steps. The main steps are:

Step I	Get Started
Step II	Planning
Step III	Generation and Evaluation of GP Options
Step IV	Implementation of GP Options
Step V	Monitoring and Review
Step VI	Sustaining Green Productivity

The project were concentrated on a number of GP techniques in the community sector such as:

- Waste Prevention and Management
- Pollution Control
- Water Supply
- Integrated Pest Management

### **2.4.3 Results from the Vietnam GPDP**

#### **a. Institutional and Organization Structure**

In order to fulfill the objectives of the project and to ensure the efficiency of project management, 3 national-level committees and a community-level committee were established.

The national-level committees were Governing Council Committee, Executive Committee and Local Experts Committee. Nine members form the Governing Council. Governing Council's functions are to give direction and advisory to Executive Committee in implementation of the project. The Executive committee consisted of six members. These core members carry out most EC meetings and copies of minutes of meetings are sent to other members. The roles of this Committee are to coordinate and carry out the implementation works, and prepare the technical reports. The Local experts committee consisted of 8 members. These local experts were responsible for auditing, analysing, consulting and evaluating all the environment issues in the village. They also conducted several training courses for villagers in their concerns.

The community-level committees i.e., the GP team, consists of nine members from the management of community and representatives of local organisations within the community such as farmer union, woman union and youth union. Among this GP team, one member was appointed to be the team leader who took all the responsibilities of GP team's activities. In order to assist the team leader, one member was assigned to be the secretary of the team. He/she was responsible for writing and keeping all minutes of meetings. Each member was responsible for one environmental issue in the community.

Beside the GP team, several organizations were involved in this project in supporting and working along with the GP team. They were namely the People's Committees from Bac Giang Province, Viet Yen District, the veteran's union, youth union, farmer's union, women union and IPM club. The supports were either finance or labor works since members of the union were mostly the villagers in the community.

#### **b. Initial Assessment of the Community**

Tinh Loc village is located in the Northeast of Bac Giang Province, about 70 km away from Hanoi. The community has a total land area of 167.6 hectares wherein cultivated area accounts for 56% (about 93.6 hectares), transportation 3.7 % and irrigation accounts for 2.7 ha. The population of Tinh Loc was 1375 persons with 301 households of which 19 % are considered poor. The villagers had an average income of 2,300,000 VND/capita/year in 1998 (equivalent to US\$ 170) which was rather low as compared to the GDP of the country (US\$325/capial/year in 1998).

The major incomes of the villagers are generated from agricultural production, including cultivating, breeding and fishing. In 1998, the income from cultivating accounted for 66% of the total income. Animal breeding contributed to 16.8 % and fishing accounted for 2%. In addition, other businesses such as trading, construction works and handicraft production have been grown up in the village to solve employment problem which contributed to 5.2% of the total income of the community. There are 4 crops per year including two rice crops and two vegetable harvesting. Highly profitable vegetables, like potatoes and soy bean had been introduced to the villagers.

#### **c. Environmental Situation and Information Collection**

The environmental situation of the demonstration village were as follows:

##### **(i) Water Sources**

The major source of water for agriculture was from the irrigation channel. The government authority controlled and ensured enough water use through out the region. Water from reservoirs flowed into the channel once or twice a week and the farmers will be charged according to their cultivating area. For domestic use, the villagers use rainwater or well water for consumption (shallow well or deep well).

Groundwater was the major source for human consumption in the village. The well water contains very high concentration of iron and manganese. Besides 90% of well water were contaminated by microorganisms. The villagers normally do not treat their water before consumption. Water quality of well water in the village is as shown in Table 2.1. As indicated in the Table, iron concentrations of wells with depth about or less than 30m are 10 to 17 times higher than that of Vietnamese standards (TCVN5944-1995). Manganese concentration was 2 to 3 times in excess of the allowable WHO's guidelines and Vietnamese standards. Coliform level was also higher than the allowable limits. At 70 meters depth, water will be considered to be suitable for drinking and cooking purpose since the iron concentration is low and no bacteria exists.

Table 2.1 Water analysis results of samples taken at different depth

No	Parameters	Samples					Vietnamese standards TCVN5944-1995	WHO's guidelines	
		Shallow well	Deep well						
		7m depth	10m depth	30m depth	45m depth	70m depth			
1	pH	6.2	6.67	6.71	6.81	6.67	6.5 – 8.5	6.5 – 8.5	
2	Color (Pt - Co)	2	1	1	1	1	5 – 50	15	
3	Hardness (mg/L)	139.64	140	142.85	143.92	140	300 - 500	300	
4	Cl <sup>-</sup> (mg/L)	7.5	7.1	7.1	7.1	7.1	200 - 600	250	
5	SO <sub>4</sub> <sup>2-</sup> (mg/L)	27	28.8	28.8	28.8	28.8	200 - 400	250	
6	NO <sub>2</sub> <sup>-</sup> (mg/L)	0.5	0	0	0	0	-	3	
7	NO <sub>3</sub> <sup>-</sup> (mg/L)	4.0	0	0	0	0	45	50	
8	Fe (mg/L)	5.2	5.1	3.1	1.5	0.2	0.3	0.3	
9	Mn (mg/L)	0.3	0.3	0.2	0.15	0.01	0.1	0.1	
10	NH <sub>4</sub> <sup>+</sup> (mg/L)	10.0	0.4	0.2	0.2	0.01	0.1	1.5	
11	Coliform (MNP/100mL)	25	10	2	0	0	0	0	

**(ii) Water Demand**

The daily water consumption for the villagers are as follows:

- Drinking water 2 L
- Cooking water 2.2 L
- Washing water 50 L

Beside human, animals also need water. Each cow or buffalo needs 30 L/day and each pig requires about 15 L/day.

Based on the preliminary audit, the community has total 300 cows and buffaloes, 1,100 pigs, and 7,800 chickens and ducks. The water demand of the whole community can be calculated and summarized in Table 2.2.

Table 2.2 Demand of potable water

	Population	Amount of necessary potable water		Total volume (liter)
		Volume	Unit	
<b>Human</b>	1,350	54.2	liter /person/day	73,170
<b>Pig</b>	1,100	15	liter /animal/day	16,500
<b>Cow and buffalo</b>	300	30	liter /animal/day	9,000
<b>Chickens and ducks</b>	7,800	20	liter /100 animals/day	1,560
<b>Total</b>				100,230

The results show that the average water demand for domestic purposes in Tinh Loc is about 100m<sup>3</sup> per day.

**(iii) Solid Waste**

In the village, solid wastes were classified into three groups, domestic, agriculture, and construction wastes. Some of the agriculture wastes such as dried wood chips, leaves, grass and paper were used as fertilizers and fuel. Other wastes were littered in many places: community roads, gardens, backyards, paddy fields and at the surface of water sources such as ponds and drainage.

Information of physical analysis of solid wastes was shown in Tables 2.3 and 2.4. Waste generation rate in Tinh Loc was about 0.112 kg/person/day which is rather low as compared to the average generation rate of 0.45 kg/person/day in other developing countries. The majority of waste in Tinh Loc were ash and dust which contributed 26.4% of the total solid waste. Plastic and rubber were the second and third largest composition with 21.1% and 16.6% respectively. No metal were found in the waste stream as it was already recycled by the villagers. The other composition such as glass, paper, ceramics were in the range of 2 to 8%. Batteries were found in the waste stream and it contributed about 2.5% to total amount of solid waste. After measuring and analyzing the sample, data of the solid waste generation

and composition of the whole community was calculated based on the obtained results. This data is shown in Table 2.5.

Table 2.3 Results of solid waste generation rate

Date	Amount of solid wastes (kg)	Number of sampling (person)	Generation rate (kg/person/day)
April, 8, 1999	15.57	124	0.125
April, 9, 1999	16.26	124	0.131
April, 10, 1999	16.67	124	0.134
April, 11, 1999	16.05	124	0.129
April, 12, 1999	10.95	124	0.085
April, 13, 1999	8.94	124	0.072
		<b>Average</b>	<b>0.112</b>

Table 2.4 Composition of solid wastes

Composition	8	9	10	11	12	13	Average (%)
Plastic	23.1	19.2	16.8	22.4	22.7	22.4	21.1
Rubber	20.1	24.4	16.8	12.5	155.2	9.9	16.6
Glass	12.8	7.3	9.6	5.0	7.6	3.6	7.7
Paper	2.6	0.0	2.4	2.5	3.8	4.5	2.7
Ceramic	10.3	4.9	7.2	10.0	5.3	13.5	8.5
Ash and dust	17.9	19.5	31.2	27.4	27.5	35.9	26.4
Textile	3.84	12.2	12.0	7.5	3.8	4.5	7.3
Organic matter	5.1	9.8	2.4	10.2	11.4	4.5	7.2
Hazardous	3.8	2.4	1.7	2.5	3.8	1.4	2.5
						<b>Total</b>	<b>100</b>

Table 2.5 Solid waste generation rate and composition in Tinh Loc

	Calculation formula	Value	Unit
<b>Generation rate</b>		0.112	kg/capita/day
<b>Population</b>		1,375	people
<b>Amount of solid waste generated</b>	$1375 * 0.112$	154	kg/day
<b>Amount of composition of waste</b>			kg/day
• Plastic	$154 * 21.1\%$	32.90	
• Rubber	$154 * 16.6\%$	25.56	
• Glass	$154 * 7.7\%$	11.86	
• Paper	$154 * 2.7\%$	4.16	
• Ceramics	$154 * 8.5\%$	13.09	
• Ash and dust	$154 * 26.4\%$	40.66	
• Textile	$154 * 7.3\%$	11.24	
• Organic	$154 * 7.2\%$	11.09	
• Hazardous	$154 * 2.5\%$	3.85	

These data indicated that in Tinh Loc of a population of about 1375 people and with the obtained waste generation rate, there would be about 154 kg of solids waste generated daily. From this, about 32.9 kg would be plastic, 25.56 kg rubber, 11.86 kg glass, 4.14 kg paper, 13.09 kg ceramic, 40.4 kg ash and dust, 11.24 kg textiles, 11.9 kg organic waste and 3.85 kg hazardous waste. The majority of waste in term of volume would be plastic. The villagers have indicated that it is difficult to recycle plastic as the amount of daily recyclable waste is not enough to collect and sell back to the factory. However, it could be possible to collect the plastic over a long period of time and the amount may then be enough for transportation. Besides plastic, paper, textiles and glass also could be collected for sale.

*(iv) Human and Animal Waste*

The community has approximately 300 cows and buffaloes, 1,100 pigs, and 7,800 chickens and ducks. The wastes generated each day are as follows:

- Human                      0.5            kg /person/day
- Poultry                     0.2            kg /animal/day
- Pig                            4              kg /animal/day
- Cow or buffalo          8              kg /animal/day

The total human and animal waste generated each day can be calculated and shown in Table 2.6.

Table 2.6 Human and animal waste analysis

	Population	Amount of waste released		Total waste
		Amount	Unit	Kg/day
<b>Human</b>	1,350	0.5	kg /person/day	675
<b>Poultry</b>	7,800	0.2	kg /animal/day	1,560
<b>Pig</b>	1,100	4	kg /animal/day	4,400
<b>Cow and buffalo</b>	300	8	kg /animal/day	2,400
<b>Total</b>				9,035

*(v) Pesticides and Fertilizers*

Earlier the villagers used traditional agricultural practices without chemical fertilizers and pesticides. Since 1980, to improve their productivity, the farmers started to introduce chemical fertilizers and pesticides. The quantities of fertilizers and pesticides used are as shown in Table 2.7. Farmers usually applied 1 ton of chemical fertilizers per year for one ha of rice. This amount included 230 kg urea, 290 kg potassium and 450 kg phosphorus. For other crops, the amount of chemical fertilizers could be twice of these amount. On the average, this community applied 100 tons of chemical fertilizers in a year including 23 tons urea, 29 tons potassium and 45 tons phosphorus which could decrease agricultural productivity in the future. Besides applying chemical fertilizers, the villagers also used about 2,000 kg of chemical pesticides per year.



Table 2.7 Chemical fertilizers and pesticides used by Tinh Loc community

<b>Names</b>	<b>Unit</b>	<b>Amount</b>	<b>Value (*1000VND)</b>
<b>Chemical fertilizers</b>	ton	100	200,000
<b>Insecticides</b>	kg	1,560	23,400
<b>Fungicides</b>	kg	260	26,000
<b>Herbicides</b>	kg	180	36,000

**d. Identify problems and their causes**

After information collection, the GP team identified the problems and analyzed their root causes through a fish bone diagram. The results are as follows:

*(i) Water Sources*

Water for cultivation was supplied through irrigation canals. The quality of this source of water was good enough for agriculture activities. In the village, there are a couple of ponds which were highly polluted by organic substances, bacteria and other fecal micro-organism. The water was turbid and contains bad odor. Shallow wells were also polluted by coliform bacteria. The water in most deep wells contained high iron and bacteria and were not suitable for drinking. Through the brainstorming of GP team, causes of water pollution were identified and analyzed. The major cause of water pollution can be attributed to human activities including wastewater, persistence of chemical fertilizers and pesticides and rubbish from community. Only iron and other metals are resulting from a geological structure factor.

*(ii) Solid Waste*

Solid wastes generated in the community were not properly managed. Solid wastes were present in many places: community roads, gardens, backyards, paddy fields and at water surface such as ponds and drainage canals. The cause analysis showed that the villagers do not have enough knowledge in handling their wastes. There were not enough funds to work on waste disposal.

*(iii) Human and Animal Waste*

Primary audit revealed that the major cause of environment problems at this village is human and animal waste management. There was no regulation concerning human and animal waste management. Human waste in this community was usually applied directly to fields or gardens without proper treatment. Most of the cattle and poultry like buffaloes, cows, and chickens, and animals like dogs and cats were set free. Therefore, surface water was easily polluted. Each household built stables and barns within their housing territory. Most of them were simple and were not equipped with the proper drainage system. Wastes were discharged into the open ditch and later entered into the community ponds. Most of the ponds were highly polluted. One of the major causes of this problem is the lack of knowledge of waste

treatment such as composting and bio-gas. There was not enough training or information dissemination to the village.

**(iv) Pesticides and Fertilizers**

The problems identified by the GP team were the rapid degradation of soil in the village, resulting in the over use of chemical fertilizer and pesticides. The identified causes were the improper use of chemical fertilizer, no knowledge of integrated pest management, bad management and improper cultivation.

**e. Option Generation and Evaluation**

**(i) Water resource**

From brainstorming and the assistance of experts, the following options were obtained:

1. Education and training should be provided to the villagers concerning environmental awareness, importance of health and potable water system.
2. Promotion of use of rain water for domestic purpose.
3. Building up a common water supply plant, including treatment plant and distribution system.
4. Building up the drainage system.
5. Repair and reconstruct animal barns to prevent wastes from polluting surface and groundwater.

The options were evaluated and the following were implemented:

- Education and training program should be provided.
- Rainwater should be used.
- Common water supply system should be built.
- Drainage system should be constructed.

**(ii) Solid Waste**

From the current situation of solid waste management, the following options were generated by GP team members of the community under the assistance of experts.

1. Training course on solid wastes should be provided to the villagers.
2. Solid waste regulation should be implemented in the village
3. Public awareness in waste reduction should be promoted.
4. Collection should be provided.
5. Integrated solid waste management should be used.

After options were generated, they were evaluated. The results were:

- Options 1 and 3 were implemented immediately.
- Integrated solid waste management should be used within the community.

**(iii) Human and Animal Waste**

By brainstorming, the following options were generated:

1. Training course concerning human and animal waste including bio-gas and composting, should be provided.

2. Public awareness should be promoted
3. Implementing bio-gas technology using concrete construction, plastic bag or brick construction.
4. Implementing aerobic composting
5. Promote the use of Vietnamese toilet.

After the options were evaluated, the following were the outcome:

- Training and Public awareness should be implemented immediately.
- Aerobic composting of garden/farm waste should be promoted.
- Bio-gas using concrete compartment should be used.

**(iv) Pesticides and Fertilizers**

By using brainstorming, the following options were generated :

1. Training on IPM and proper cultivation method should be provided.
2. Public awareness on IPM should be promoted
3. Organize the IPM model households as demonstration project.
4. Introducing new seeds and new plants for more effective cultivation.
5. Introducing bio-fertilizer and bio-pesticides.

After the options were evaluated, the following were the options for implementation:

- Training and public awareness should be implemented immediately.
- Organization of IPM model households should be implemented
- Bio-fertilizer and bio-pesticides should be introduced.

**f. Implementation and Results**

The implementation of each options were summarized as followed:

**(i) Drinking water**

Through training courses, the villagers were aware of the importance of using potable water for preventing water borne diseases. A common water supply plant was constructed which can supply 150 m<sup>3</sup>/day of sanitary water (without bacteria and low iron concentration). The villagers will also build a pipe network to every household in the future. Total investment of this center was about 300 millions VND (equivalent to about US\$ 21,000)

**(ii) Wastewater**

A 1.5 km long drainage system was constructed in the village to collect all wastewater to the existing ponds. The problem of stagnant water in the community was eliminated.

**(iii) Solid waste**

The training program on solid waste was very effective as most of the villagers knew how to analyze their waste. Integrated solid waste management system was started. The collection system in the village was established with waste segregation program. Hazardous and non-recyclable wastes were transported to a sanitary landfill 1 km away from the village. Litter

disappeared from the village. The image of the village was significantly improved since the wastes were rarely present on the streets and other public places.

*(iv) Human and animal wastes*

Three concrete compartment bio-gas plants were constructed in the village. The farmers collected their animal and human waste and put them into the reactors. As a result, the ones who owned the reactor had bio-gas for cooking, and bio-fertilizer for agriculture use. One of the most important issues was that the environment of these households was protected. Nasty odor of the human and animal waste is almost eliminated from the environment. The cost of the concrete compartment reactor was about 2 millions VND (US\$140) per cubic meter. The cost of brick reactor was about 1 millions VND (US\$70) per cubic meter. The brick model seemed to be more suitable than the concrete compartment. The villagers decided to build more in the village.

Composting was introduced in the village. Two households implemented aerobic composting with the addition of microorganism. The results show that this method generated bio-fertilizer after 2 composting – weeks. By using the bio-fertilizer, these two households could decrease the use of chemical fertilizer and pesticide.

*(v) Management of using agriculture chemical*

Even though IPM was not new to Vietnam, only 30% of households in this village were implementing IPM in their farms. After the promotion of IPM in the village, number of households implementing increased up to 95% of the total households in the village. Primary result showed that the amount of chemical fertilizers used by the villagers decreased by 33% in 1999.

#### **2.4.4 Summary**

The result from this green productivity demonstration project in Vietnam demonstrated the effectiveness of GP methodology application in the community level. The community development could be enhanced and the management could be very effective through GP implementation.

### **2.5 The necessity of Bio-gas in Community Development**

Community in most developing countries depends on their agricultural products. In many countries, farmers use their farm animals such as buffaloes, oxen and cows in soil preparing work. Horses have been used in farm transportation for centuries. Apart from these farm animals, villagers in the community raise other animals such as chickens, hens, ducks, pigs, and sheep for their food supply and extra income. All these animals are normally raised in the vicinity of their boundaries and in barns within the housing area. Some animals are set free and roaming around the housing area. Therefore, animal wastes are litter around the area and it could become health hazard to human being.

Major energy consumption of community in developing countries are mainly lighting and energy for cooking. The luxury of hot water bathing, air conditioning is unheard of. If electricity is available in the community, villagers will use electricity for lighting. However,

most villagers will use charcoal or wooden fuel for cooking as they are considered more or less free of charge. Villagers normally will enter the near-by forest area and cut down tree for making charcoal or cut wood for cooking purpose. This activity certainly creates deforestation in many developing countries.

With these two factors in mind bio-gas should be a good alternative in both waste treatment and alternative energy source.

### 2.5.1 Waste Generation and Management in Community

In a small community, normally one village will raise animals for farming and for food. The normal trend is that a family of 4-6 members will have one ox or one horse or one buffalo for farming and transportation, 4-5 pigs for food and extra income, and 30-40 poultry for food. With this assumption, waste generated for a family will be as follows:

• From Human	0.5x6	=	3.0	kg/day
• From ox or horse or buffalo	8x1	=	8.0	kg/day
• From pigs	5x4	=	20.0	kg/day
• From poultry	0.2x40	=	8.0	kg/day
Total		=	39.0	kg/day

Normally, human waste will be put in septic tank or latrine so that soil can reduce the pollution level. However, risk for groundwater contamination is very high. Animal wastes are either used directly in farm, or turning to compost, or sometimes discharged directly into nearby stream. All these activities can create risk on human health.

### 2.5.2 Energy Consumption in Community

In most villages, a family of 5-6 will need energy for their living as follows:

- Energy for cooking for 3 meals
- Energy for lighting for approx. 3-4 hours per day
- Energy for appliances such as refrigerator, fan, TV, radio, etc

In the remote area, energy for cooking is mainly from wood or charcoal that the community may obtain it freely in the forest. Lighting and other appliances will need electricity power supply. The amount of energy needed depend on the quality of life in that community. However, no matter what, the energy consumption will mean expenses in the family. In many part of the world, deforestation due to energy consumption for cooking and house warming is a big issue.

### 2.5.3 Design of Bio-gas for Community

With the above reason, bio-gas could be a very good alternative for pollution control and energy sources. The use of anaerobic digestion of organic waste materials, such as farm manure, litter, garbage, and night-soil, accompanied by the recovery of methane for fuel, has been an important development in rural sanitation during the last few decades. This development is basically an extension of the anaerobic process for sludge digestion used in municipal sewage treatment to small digestion-tank installations on farms. These farm plants

comprise one or more small digesters and a gas-holder. Manure and other wastes are placed in a tank which is sealed from atmospheric oxygen, and are permitted to digest anaerobically. The methane gas, which is produced during the anaerobic decomposition of the carbonaceous materials, is collected in the gas-holder for use as fuel for cooking, lighting, refrigeration, and heating, and for other domestic or agricultural purposes, such as providing power for small engines.

With the amount of waste generation of 39 kg/day, the size of bio-gas reactor could be about 8 cubic meters. With this size, gas produced would be about 1.4-2.3 cubic meters per days. The amount of gas produced could be used for 3-5 hours of cooking or 8-13 hours of lighting. Apart from this, the family will obtain 15 kg/day of good compost which may be able to use in their farms. The family could save money for energy and fertilizer. Besides, with the bio-gas reactor in the vicinity of housing boundary, the environmental situation will be much better and the quality of life will be improved. Therefore, bio-gas could be a good alternative in community development.

## CHAPTER 3

### Review Of Bio-Gas Technology

#### 3.1 Bio-Gas Technology

Bio-gas technology is the transformation of solid waste through anaerobic digestion process to obtain bio-gas such as methane.

##### 3.1.1 Process Microbiology

The biological conversion of the organic fraction of municipal solid waste under anaerobic conditions is thought to occur in three steps. The first step involves the enzyme-mediated transformation (hydrolysis) of higher-molecular-mass compounds into compounds suitable for use as a source of energy and cell tissue. The second step involves the bacterial conversion of the compounds resulting from the first step into identifiable lower-molecular-mass intermediate compounds. The third step involves the bacterial conversion of these intermediate compounds into simpler end products, principally methane and carbon dioxide.

In the anaerobic decomposition of wastes, a number of anaerobic organisms work together to bring about the conversion of the organic portion of wastes into a stable end product. One group of organism is responsible for hydrolyzing organic polymers and lipids to basic structural building blocks such as fatty acids, monosaccharides, amino acids, and related compounds. A second group of anaerobic bacteria ferments the breakdown products from the first group to simple organic acids, the most common of which is acetic acid. This second group of microorganisms, described as nonmethanogenic, consists of facultative and obligate anaerobic bacteria that are often identified in the literature as “acidogens” or “acid formers”.

A third group of microorganisms converts the hydrogen and acetic acid formed by the acid formers to methane gas and carbon dioxide. The bacteria responsible for this conversion are strict anaerobes, called methanogenic, and are identified in the literature as “methanogens” or “methane formers”. Many methanogenic organisms identified in landfills and anaerobic digesters are similar to those found in the stomachs of ruminant animals and in organic sediments taken from lakes and river. The most important bacteria of the methanogenic group are the ones that utilize hydrogen and acetic acid. They have very slow growth rates; as a result, their metabolism is usually considered rate-limiting in the anaerobic treatment of an organic waste. Waste stabilization in anaerobic digestion is accomplished when methane and carbon dioxide are produced. Methane gas is highly insoluble, and its departure from a landfill or solution represents actual waste stabilization.

##### 3.1.2 Environmental Factors

To maintain an anaerobic treatment system that will stabilize an organic waste efficiently, the nonmethanogenic and methanogenic bacteria must be in a state of dynamic equilibrium. To establish and maintain such a state, the reactor contents should be void of dissolved oxygen and free of inhibitory concentrations of free ammonia and such constituents as heavy metals and sulfides. Also, the pH of the aqueous environment should range from 6.5 to 7.5. As the

methane bacteria cannot function below this point, sufficient alkalinity should be present to ensure that the pH will not drop below 6.2. When digestion is proceeding satisfactorily, the alkalinity will normally range from 1000 to 5000 mg/L and the volatile fatty acids will be less than 250 mg/L. Values for alkalinity and volatile fatty acids in the high-solids anaerobic digestion process can be as high as 12,000 and 700 mg/L, respectively. A sufficient amount of nutrients, such as nitrogen and phosphorus, must also be available to ensure the proper growth of the biological community. Depending on the nature of the sludges or waste to be digested, growth factors may also be required. Temperature is another important environmental parameter, with optimum temperature in the mesophilic, 30 to 38°C (85 to 100°F), and the thermophilic, 55 to 60°C (131 to 140°F) range.

### 3.1.3 Gas Production

The general anaerobic transformation of solid waste can be described by means of the following equation.

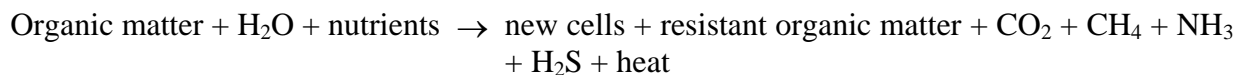

### 3.1.4 Bio-Gas

Bio-gas is a gas generated from the anaerobic digestion of organic waste. It consists of CH<sub>4</sub> (50-70%), CO<sub>2</sub> (30-50%) with the remaining gases being: H<sub>2</sub>, O<sub>2</sub>, H<sub>2</sub>S, N<sub>2</sub> and water vapor. To ensure optimal Bio-gas production, the three groups of micro-organisms must work together. In case of too much organic waste, the first and second groups of micro-organisms will produce a lot of organic acid which will decrease the pH of the reactor, making it unsuitable for the third group of micro-organisms. This will result in little or no gas production. On the other hand, if too little organic waste is present, the rate of digestion by micro-organisms will be minimal and production of Bio-gas will decrease significantly. Mixing could aid digestion in the reactor but, too much mixing should be avoided as this would reduce bio-gas generation. Table 3.1 shows the amount of bio-gas generated from animal waste and agriculture residue.



Table 3.1 Amount of bio-gas generated from animal waste and agriculture residue

animal	gas produced L/kg-solid
Pig	340-550
Cow	90-310
Chicken	310-620
Horse	200-300
Sheep	90-310
Straw	105
Grasses	280-550
Peanut shell	365
Water Hyacinth	375

### 3.1.5 Factor Affecting Gas Generation

To ensure a constant generation of gas, the following factors should be considered :

- Organic waste should be sufficient at all time.
- Daily input of waste should conform with reactor size. Too much input will reduce the gas generation rate.
- Digestion period (retention time) should be about 60-80 days

$$\text{Digestion period} = \frac{\text{Volume of reactor}}{\text{Daily input of waste}}$$

- pH within reactor should be about 7.0-8.5. Too low a pH will inhibit gas production.

### 3.1.6 Benefit of Bio-Gas Technology

The following benefits will be obtained from bio-gas technology:

- Energy

Bio-gas could be used as a fuel alternative to wood, oil, LPG and electricity.

- Agriculture use

Sludge from the bio-gas reactor could be used as compost. Organic nitrogen from waste will be transformed into ammonia nitrogen, a form of nitrogen which plants can uptake easily.

- Protect environment

Using bio-gas technology on animal waste treatment will reduce risk of infection from parasite and pathogenic bacteria inherent in the waste. Odor and flies will be significantly reduced in the area, and water pollution created by the dumping of waste can also be prevented.

### 3.2 Review of Bio-Gas Reactor

The anaerobic digestion of organic waste materials, such as farm manure, litter, garbage, and night-soil, accompanied by the recovery of methane for fuel, has been an important development in rural sanitation during the last few decades. This development is basically an extension of the anaerobic process for sludge digestion used in municipal sewage treatment to small digestion-tank installations on farms. These farm plants comprise of one or more small digesters and a gas-holder. Manure and other wastes are placed in a tank which is sealed from atmospheric oxygen, and are permitted to digest anaerobically. The methane gas, which is produced during the anaerobic decomposition of the carbonaceous materials, is collected in the gas-holder for use as fuel for cooking, lighting, refrigeration, and heating, and for other domestic or agricultural purposes, such as providing power for small engines.

This method provides for the sanitary treatment of organic wastes, satisfactory control of fly-breeding, efficient and economical recovery of some of the waste carbon as methane for fuel, and retention of the humus matter and nutrients for use as fertilizer.

Most of the farm installations have, so far, utilized only animal manure and organic litter; however, night-soil can be satisfactorily treated together with the other wastes in these digesters if adequate digestion time is allowed to permit the destruction of the pathogenic organisms and parasites. Such a practice has many advantages on farms and in villages where water-carried sewage disposal is not available. The use of the digestion tank can eliminate the dangerous insanitary practice of allowing night-soil to be deposited on fields, and in the immediate environment of homes, without proper treatment. Straw, weed trimmings, or any other type of cellulose materials may be digested together with the manure and night-soil for the production of methane.

Digester tanks with gas collection are particularly advantageous in areas which are short of fuel and where animal dung is burned for cooking. The burning of dung destroys, with digestion, the valuable nitrogen and other nutrients which could be used as fertilizer. The nitrogen, phosphorus, potash, and other nutrients are retained in the tank as humus and liquid while much of the carbon and hydrogen are evolved as methane, for collection and use as fuel. The quality of the humus is similar to that obtained from aerobic composting, and when the liquid is utilized together with the solids as fertilizer, practically all of the fertilizer nutrients are reclaimed.

The evolved gas, which consists approximately of two-thirds methane and one-third carbon-dioxide, will contain 4500 to 6000 calories per cubic metre, thus providing a convenient source of heat at low cost. One cubic metre of the gas at 6000 calories is equivalent to the following quantities of other fuels : 1,000 litres of alcohol; 0.800 litres of petrol; 0.600 litres of crude oil; 1.500 m<sup>3</sup> of commonly manufactured city gas; 1.400 kg of charcoal; and 2.2 kilowatt-hours of electrical energy.

The gas can be stored in the gas-holder and piped into the house to provide clean fuel for cooking and lighting. It has a slight barn-yard odour by which any leaks can be readily detected, and a very low toxicity since it contains very little carbon monoxide—the toxic constituent of most city gas. It burns with a violet flame without smoke. Since a considerable amount of CO<sub>2</sub> is mixed with the methane, the risk of fire or explosion is

somewhat less than in the case of city gas. However, every precaution should be taken to avoid obtaining a mixture of methane and air, except when the methane is burned as an open flame. Mixtures of 5% - 14% methane in air are explosive when large quantities are ignited.

There are several basic factors to be considered when constructing or purchasing a digester installation. These are : (1) climate; (2) single or multiple family installations; (3) amount of wastes available; (4) gas production; (5) location of digesters; (6) gas requirements and storage.

### **3.2.1 Climate**

Small digester plants can be used most effectively in temperate climates, where freezing temperatures are infrequent and of short duration. Decomposition and gas production are most rapid at about 35°C, but are satisfactory at temperatures between 15-20°C. Gas production practically ceases at temperatures below 10°C.

### **3.2.2 Single or Multiple Family Installations**

Either single or multiple family installations can be provided, depending on whether the family has sufficient manure and other wastes to operate a unit. A minimum single family installation would normally include a digester tank of about 4-5 m<sup>3</sup> capacity and a gas-holder of at least 2 m<sup>3</sup> capacity. Two or more digesters are desirable so that there will not be an interruption of gas production and so that one tank may be loaded while the other is digesting. A single gas-holder can serve more than one digester unit. If two or more families living in adjacent compounds do not have more than one farm animal each, it may be advantageous to combine their wastes into one digester installation from which the gas could be distributed to each dwelling.

### **3.2.3 Amount of Wastes Available**

As indicated, horses and cows produce between 10 to 16 metric tons of manure per year, depending on stabling conditions and amounts of organic litter used for bedding. To this amount, garbage, waste straw, cane stalks, or any other organic litter may be added. Where night-soil is used as a fertilizer, it should be digested with the other organic wastes before application to the land, in order to prevent the spread of fecal-borne diseases. While human excrement does not add much weight to the digester (15-30 kg per capita per year) it does provide appreciable quantities of the nitrogen and phosphorus necessary for the biological digestion and methane production of cellulose and other materials with a high carbon content.

### **3.2.4 Gas Production**

In practice, about 50% of the carbon theoretically available for gas production is converted into gas. A metric ton of waste will normally yield about 50-70 m<sup>3</sup> of gas per digestion cycle, depending upon the proportion of organic matter and the carbon content of the waste.

The digestion cycle will be shorter at high temperatures than at low temperatures, and the daily yield per ton of material will be greater. Considerably greater digester-capacity is required to produce a fixed amount of gas at a temperature of about 20°C than at a

temperature of 30-35°C. Mignotte<sup>54</sup> gives the following estimates for gas production per ton of manure for different digestion periods at different temperatures :

Temperature (°C)	Gas production (m <sup>3</sup> per day)	Digestion period (months)
15	0.150	12
20	0.300	6
25	0.600	3
30	1.000	2
35	2.000	1

### 3.2.5 Location of Digesters

The digesters should be located near the source of manure and waste material to avoid excessive handling and transportation. Also it is desirable to place them so as to minimize the amount of gas piping required.

### 3.2.6 Gas Requirements and Storage

The gas may be used for domestic purposes, such as cooking, heating water, food refrigeration, and lighting. The following are some approximate quantities of gas for these different uses : domestic cooking, 2 m<sup>3</sup> per day for a family of five or six people; water heating, 3 m<sup>3</sup> per day for a 100-litre tank or 0.600 m<sup>3</sup> for a tub bath and 0.35 m<sup>3</sup> for a shower bath; domestic food refrigeration, 2.5-3 m<sup>3</sup> per day for a family of five or six people; lighting, 0.100-150 m<sup>3</sup> per hour per light.

Since the gas is produced continuously, day and night, but is used largely during the daytime, it is necessary to provide storage facilities so that the gas will not be wasted and will be available when needed. The storage capacity should be estimated to meet peak demands. For small installations, storage capacity of about one day's requirement of gas should be provided. The volume of the gas-holder should not be less than about 2 m<sup>3</sup>, even for very small installations.

The gas-holder may be circular or square and should be provided with a water seal to prevent the escape of gas or admission of air. The weight of the floating cover of the gas-holder provides the gas pressure.

### 3.3 Example of Digesters

Some examples of digesters are shown in Figures 3.1-3.6. They are individual digester unit, manure gas plant with latrine, digester and latrine, gas holder for manure gas plant and manure digester with floating cover for gas holder.

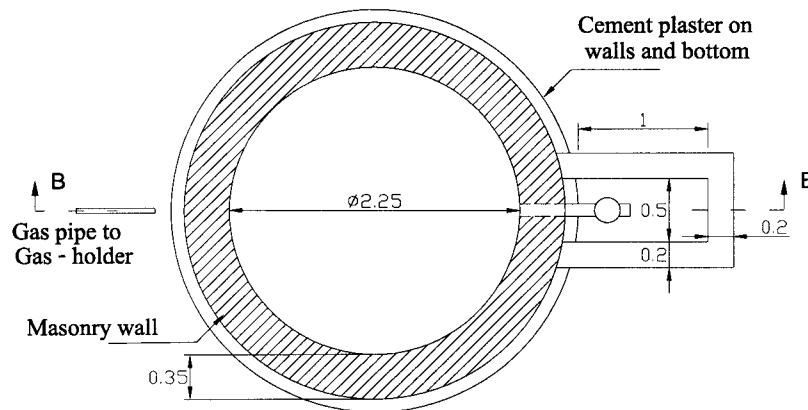

*All Measurements are in metres*  
**Figure 3.1 Plan of Individual Digester Unit**

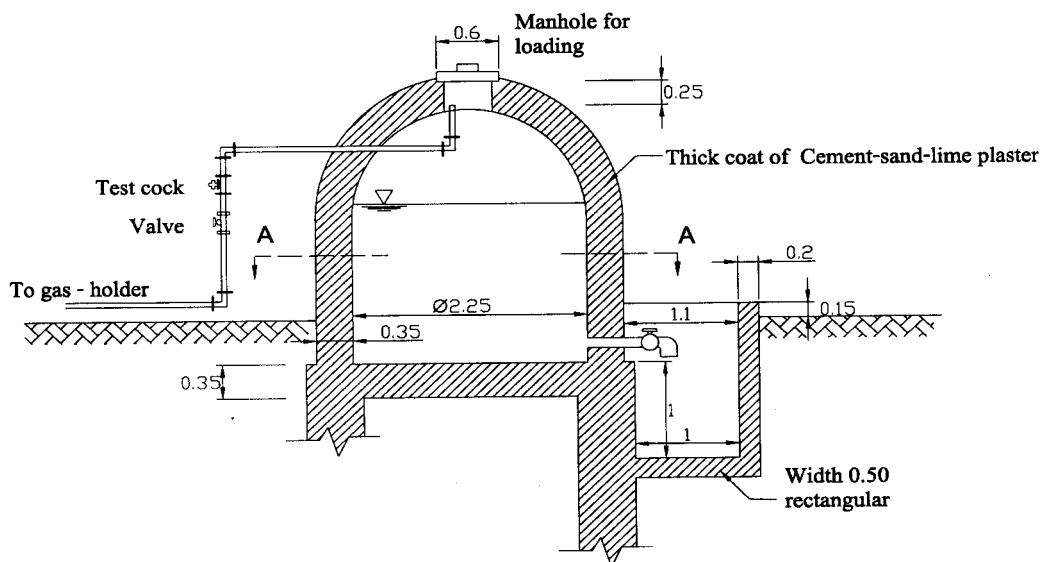

*Maximum manure - storage capacity of digester : 7.860*  
 $m^3$

*All Measurements are in metres*  
**Figure 3.2 Cross Section of Individual Digester Unit**

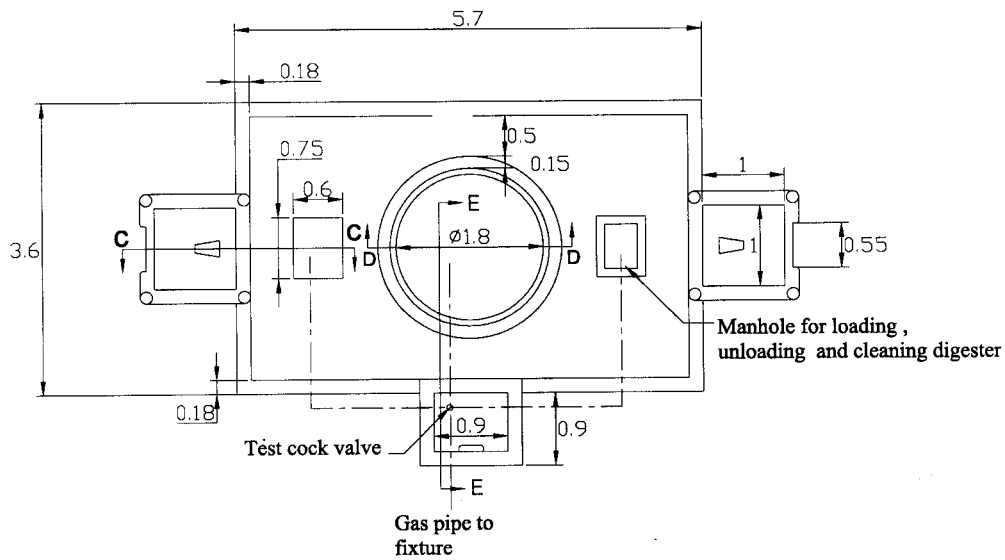

*All Measurements are in metres*

Figure 3.3 Plan of Manual Gas Plant with Latrines

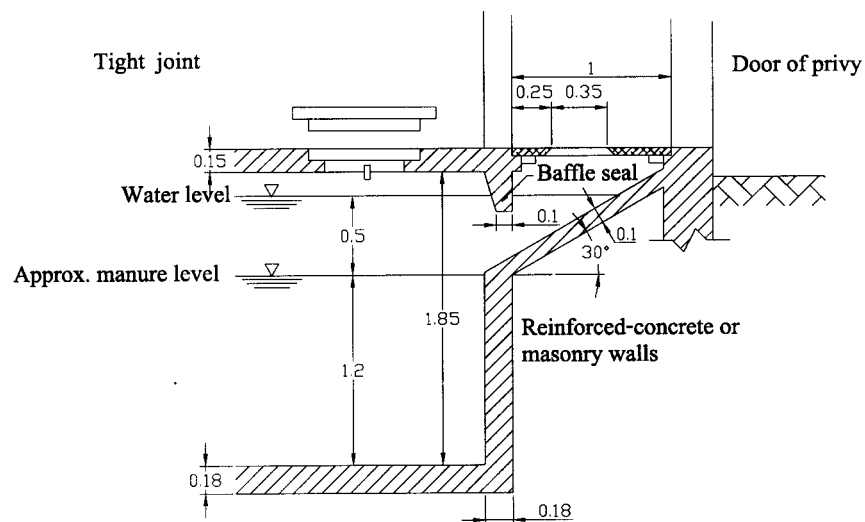

*All Measurements are in metres*

Figure 3.4 Cross Section of Digester and Latrines

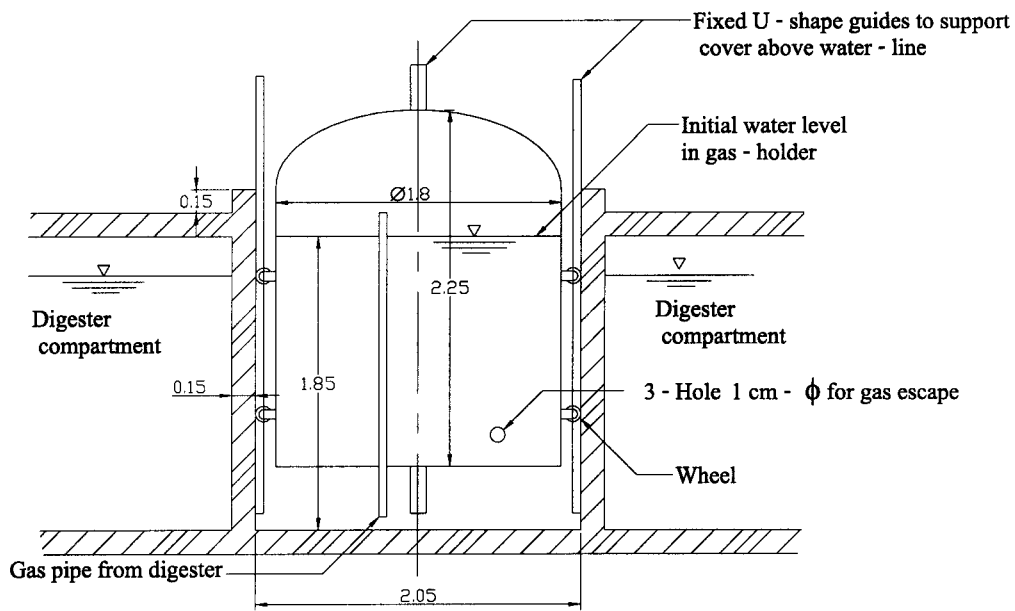

*All Measurements are in metres*

**Figure 3.5 Cross Section of Gas - Holder for Manure Gas Plant**

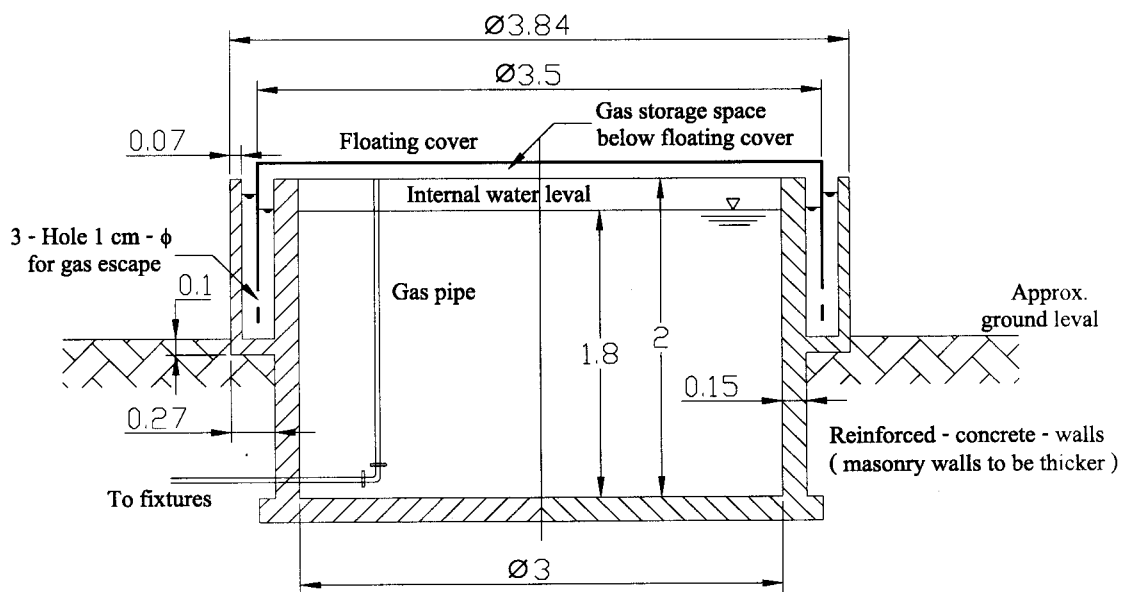

*All Measurements are in metres*

**Figure 3.6 Cross Section of Manure Digester with Floating Cover for Gas - Holder**

## CHAPTER 5

### Steps of Bio-gas Reactor Construction

#### 5.1 Step 1

##### 5.1.1 The strength of the chamber depends on beams

After the excavation is completed, the ground soil must be well pressed. Piles are required at the foundation in places where the ground is soft or filled with water or liquid. The crack will appear if the chamber is sinking. Set the level of beams using level line and marked with peg. (Figure 5.1)

2.00meters	➤	4.6 m <sup>3</sup>	3.13 meters	➤	30 m <sup>3</sup>
2.34 meters	➤	8 m <sup>3</sup>	3.57 meters	➤	30 m <sup>3</sup>
2.37 meters	➤	12 m <sup>3</sup>	4.04 meters	➤	30 m <sup>3</sup>
2.62 meters	➤	16 m <sup>3</sup>			

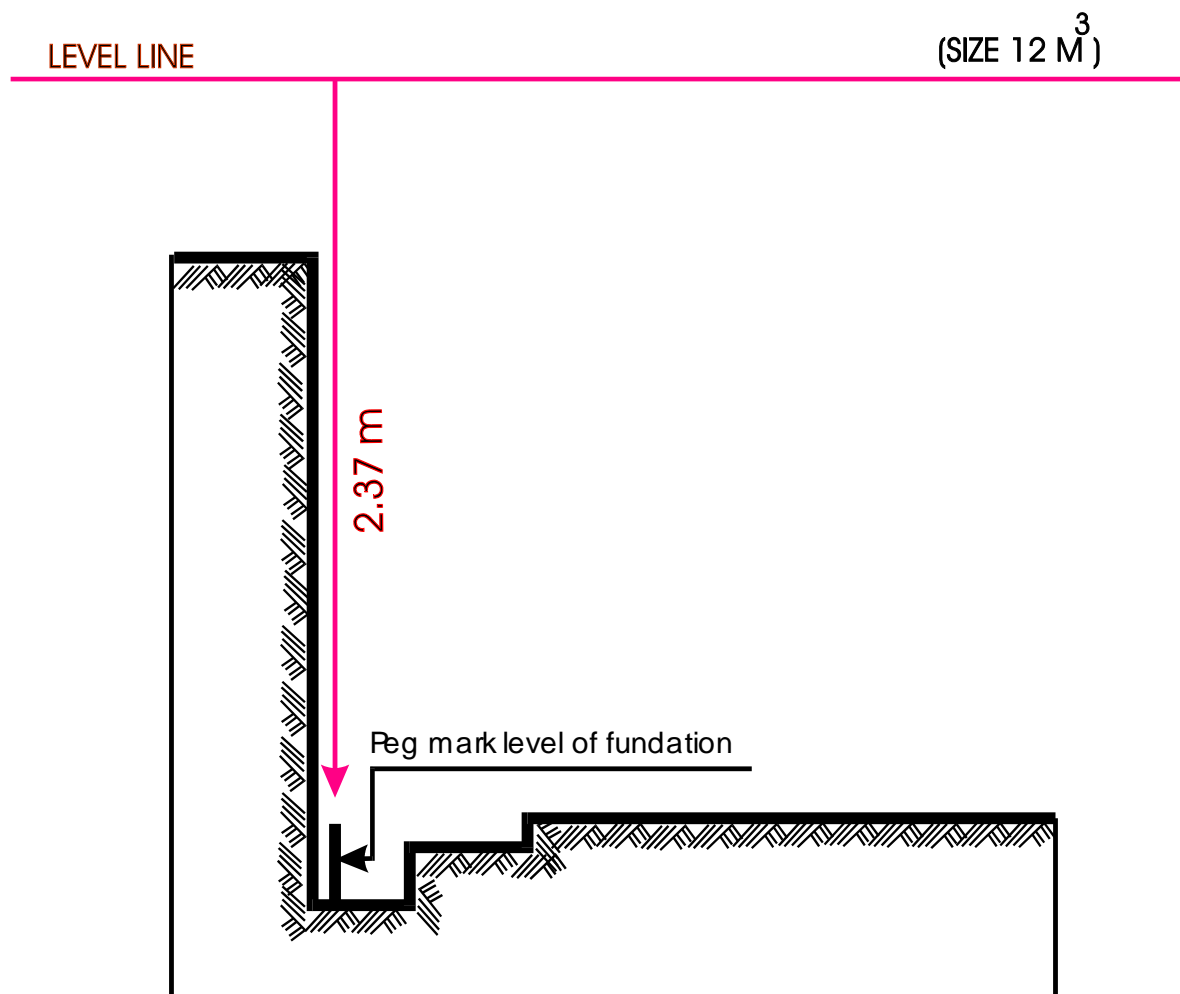

Figure 5.1 strength of the chamber depends on beams



Fill the foundation edge up to the same level as the ground with a mixture of cement 1 bucket : coarse sand 2 buckets : gravel 4 buckets (1 : 2 : 4 / volume). The mixture can be poured directly on the hard ground but fill the floor with coarse sand or gravel first if the ground is soft. While the cement is setting, cast the first layer of brickwork to allow the sufficient time for the bricks to attach to the cement base. The radius of brickwork is

1.30 meters	➤	4.6 m <sup>3</sup>	2.55 meters	➤	30 m <sup>3</sup>
1.57 meters	➤	8 m <sup>3</sup>	3.00 meters	➤	50 m <sup>3</sup>
1.80 meters	➤	12 m <sup>3</sup>	3.58 meters	➤	100 m <sup>3</sup>
2.05 meters	➤	16 m <sup>3</sup>			

Ram half of the brick into the cement base and scrape the surface of the outer beam.  
(Figure 5.2)

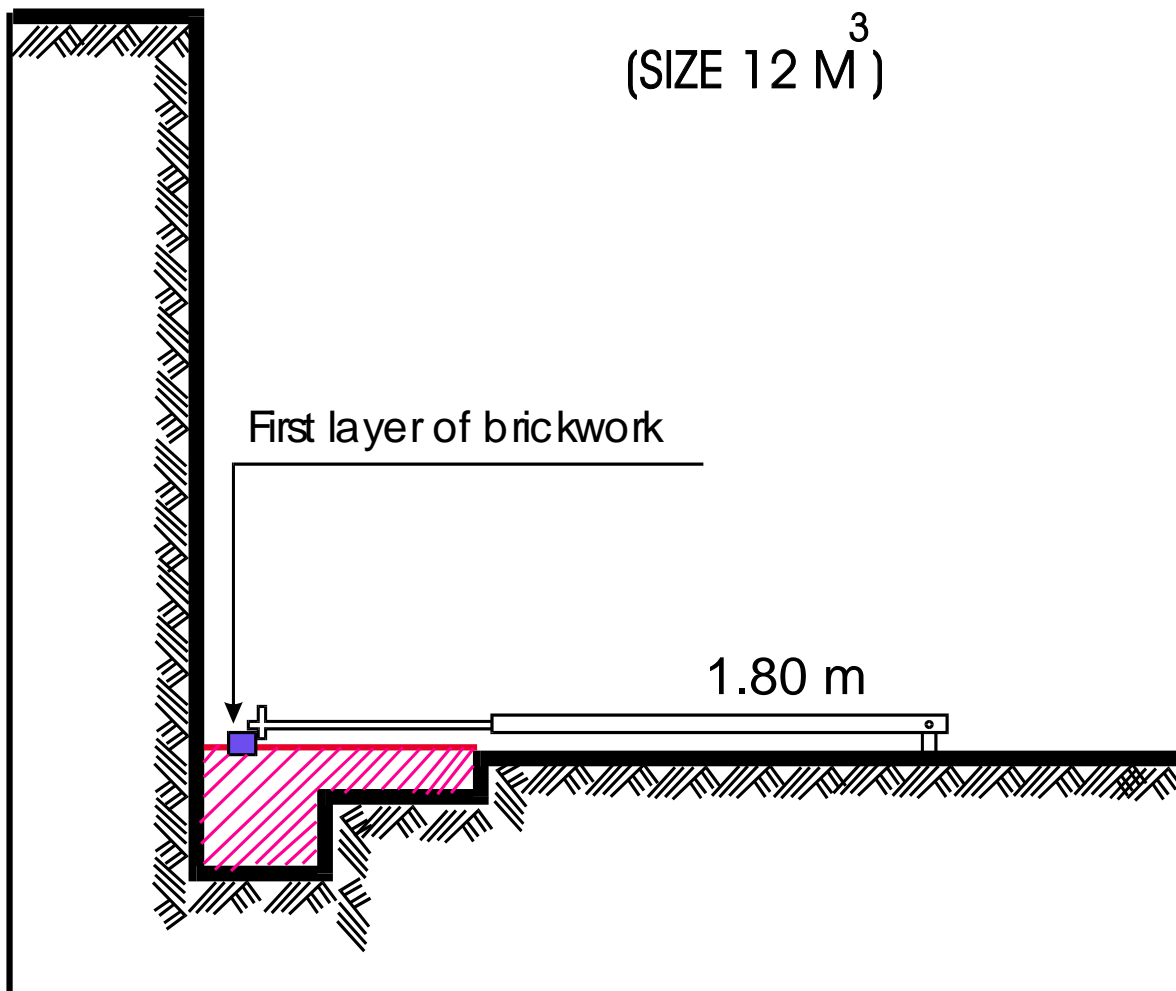

**Figure 5.2 First layer of brick work**

### 5.1.2 How to Line the Walls

When the first layer of brickwork was attached to the base, soak the bricks prepared for the next layer in water in order to wash out dust and to help the brick to settle better with cement. Concrete mixture is cement 1 bucket : lime 1/3 bucket : coarse sand 2.5 buckets (1 : 1/3 : 2.5 per volume). Set line for each brick using radius stick

1.30 meters	➤	4.6m <sup>3</sup>	2.55 meters	➤	30 m <sup>3</sup>
1.57 meters	➤	8 m <sup>3</sup>	3.00 meters	➤	50 m <sup>3</sup>
1.80 meters	➤	12 m <sup>3</sup>	3.58 meters	➤	100 m <sup>3</sup>
2.05 meters	➤	16 m <sup>3</sup>			

Radius stick must be used with each layer of brick to keep the radius constant.(Figure 5.3) Joints should be offset and finish consecutively one layer after the other until 4 layers has been completed. Stop working and wait for the cement to dry after casting the third layer of brickwork - 10cm above the ground, place the outlet pipe then continue casting.

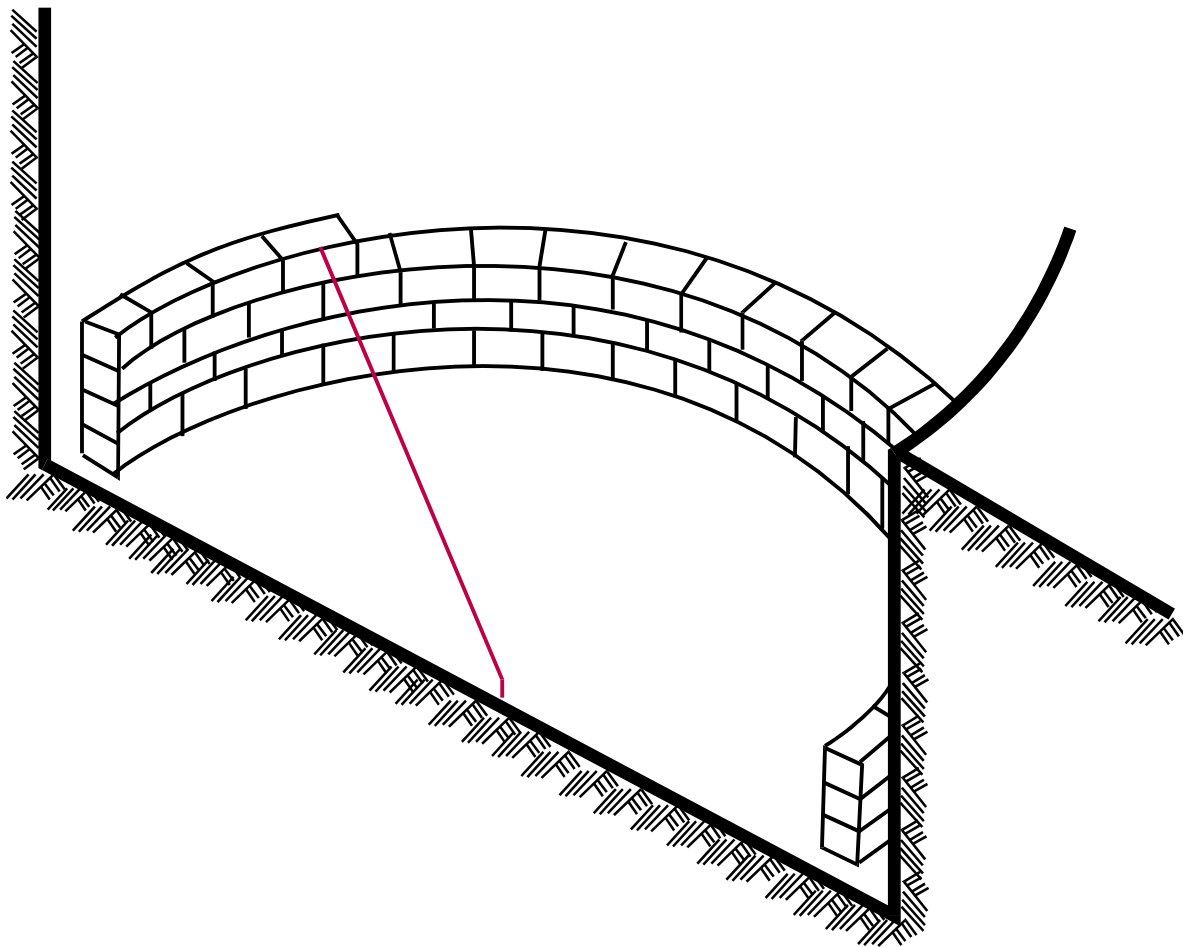
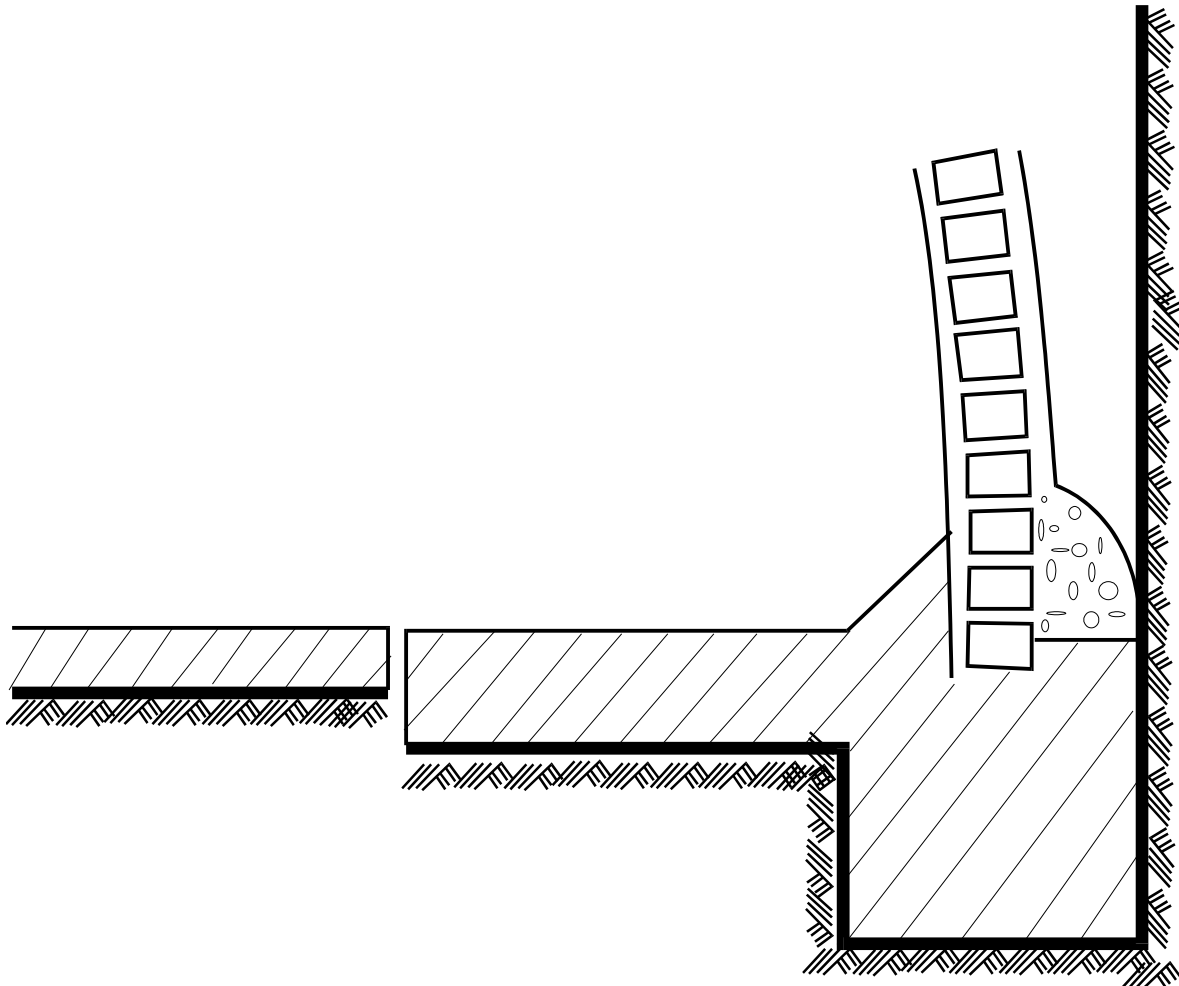

Figure 5.3 layer of brick to keep the radius stick constant

Seal the outside of the wall 3 layer high with cement mortar. Cement mixture is cement 1 bucket : coarse sand : 2 buckets : gravel 4 buckets (1 : 2 : 4 per volume). (Figure 5.4)  
 When the layer is 1.60 meters measured from level line, leave a hole to place outlet pipe and inlet pipe (measure from the level line to the end of pipes). Continue casting until the level of brick work is

1.50 meters	➤	4.6 m <sup>3</sup>	1.44 meters	➤	30 m <sup>3</sup>
1.44 meters	➤	8 m <sup>3</sup>	1.78 meters	➤	30 m <sup>3</sup>
1.29 meters	➤	12 m <sup>3</sup>	2.04 meters	➤	30 m <sup>3</sup>
1.38 meters	➤	16 m <sup>3</sup>			

Stop casting and leave it to dry. Apply the outside wall with plaster 1 cm thick using the same mixture as for building wall.



**Figure 5.4 Seal the outside of the wall 3 layer high**

### 5.1.3 Lower Outlet Pip and Storage Tank

This is for bio-gas plant that is filled with pig excrement. The residue of pig excrement is harder and sinks faster causing blockage. This 8 or 10 inch PVC diameter outlet pipe is rested at the bottom of the digester chamber wall. The bottom edge of the pipe is connected to the brickwork when it was constructed 10 cm or 3 layers above the floor ground (Figure 5.5). Before placing the pipe, use saw to scrape the outside of the pipe to let the cement settle better and to prevent seeping of water. At the upper end of the pipe build a square pit near the expansion chamber. The bottom floor of the storage tank is at the same level as the expansion chamber. The size of the storage tank is 25 cm (width) x 30 cm (length) x 60 cm (Height). There is an alley connected to outlet pipe of the expansion chamber or to storage tank to collect manure (Figure 5.6).

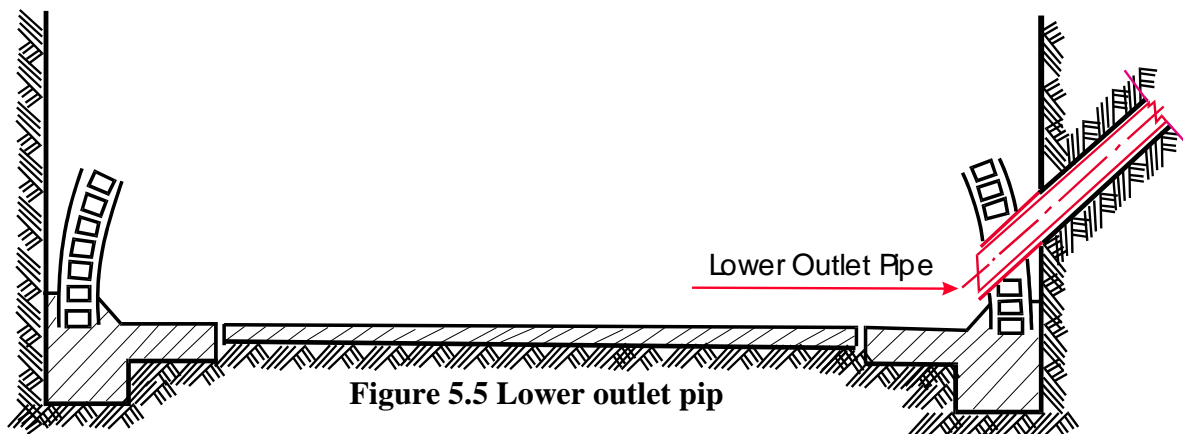

Figure 5.5 Lower outlet pip

### Figure 14 Lower Outlet Pip

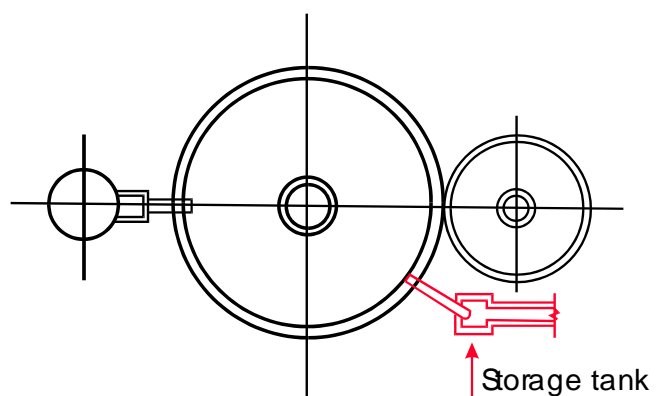

Figure 5.6 Slurry box drainage

### 5.1.4 Inlet Pipe

The end of Inlet pipe is rests 1.60 meters from the level line. PVC pipe (or concrete pipe diameter 8 –10 inch) is required. Scrape the outside of PVC mixing pipe by saw to let the cement settle well and prevent seepage of water. Locate where the pipe should be placed and ram the pipe well into cement and keep the pipe in position with pegs.(Figure 5.7 )

<b>1.60 meters</b>	➤	4.6,8,12,16 m <sup>3</sup>
<b>1.74 meters</b>	➤	30 m <sup>3</sup>
<b>2.08 meters</b>	➤	50 m <sup>3</sup>
<b>2.14 meters</b>	➤	100 m <sup>3</sup>

□

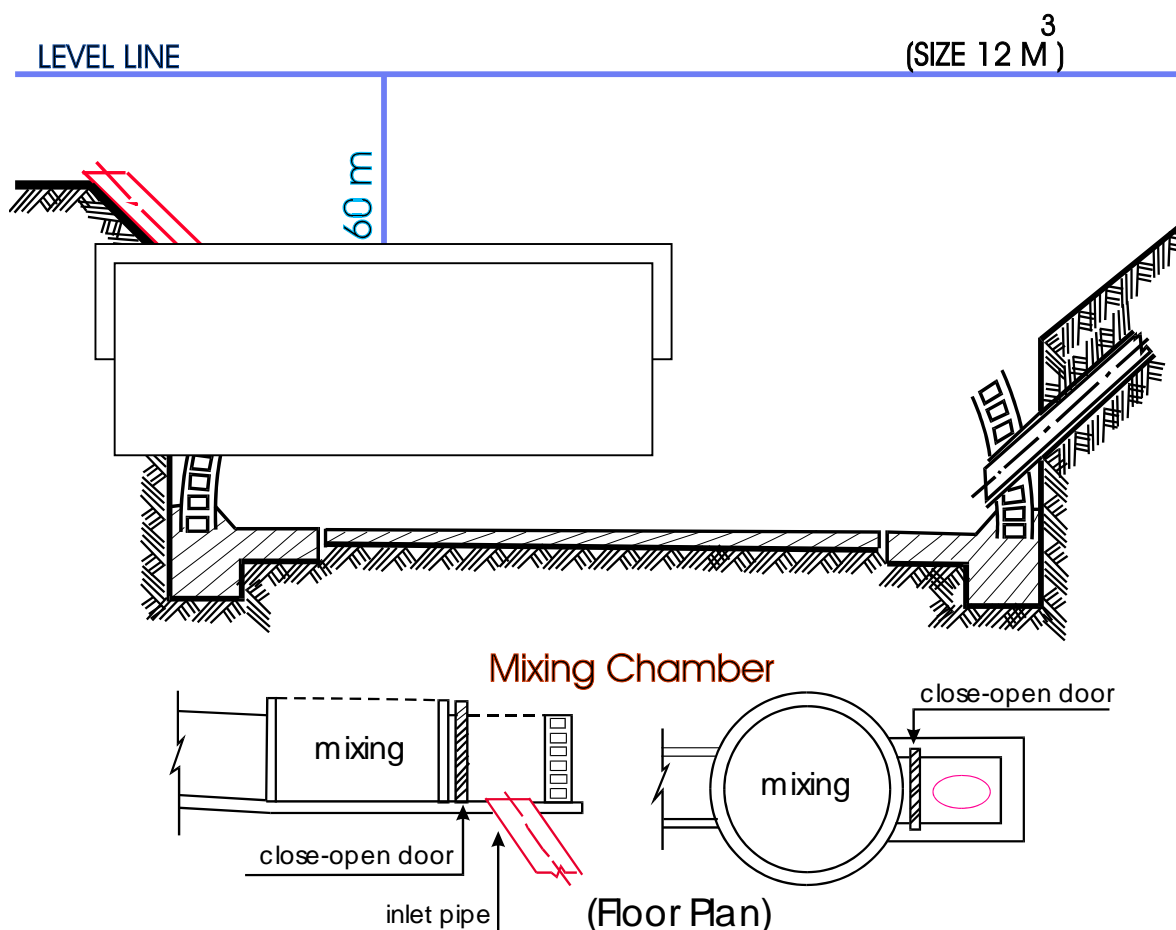

Figure 5.7 Inlet pipe

### 5.1.5 Outlet Pipe and Gas Control Pipe

**Outlet pipe** drains slurry and manure that had been broken down and stores them in expansion chamber. At the same time it controls gas pressure inside the chamber by releasing out exceeding gas or when gas is not being used. This prevents the wall of the chamber from exposing to high pressure. Increasing the life span of the gas chamber. The outlet pipe is made of concrete with diameter 10-12 inch. The bottom of the pipe is placed at the same level of weak ring, measured from reference line to the top edge of the pipe

1.35 meters	➤	4.6 m <sup>3</sup>	1.44 meters	➤	30 m <sup>3</sup>
1.44 meters	➤	8 m <sup>3</sup>	1.78 meters	➤	50 m <sup>3</sup>
1.29 meters	➤	12 m <sup>3</sup>	2.04 meters	➤	100 m <sup>3</sup>
1.38 meters	➤	16 m <sup>3</sup>			

The inside of the top of the pipe must be lined straight to a string that is tied to the level line at 90° to the center of the expansion chamber. Pour cement under the pipe for supporting and the pipes are kept in position by pegs. Continue the rest of the brickwork and face the concrete outside wall (Figure 5.8).

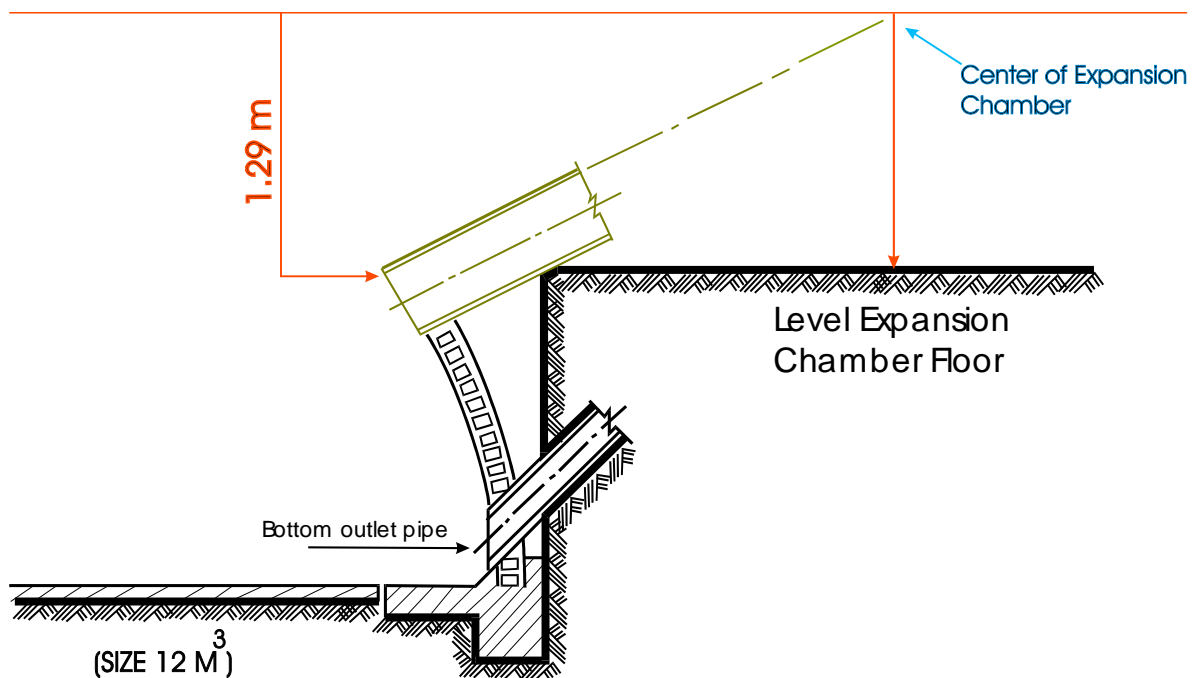

**Figure 5.8 Outlet pipe & Gas control**

### 5.1.6 Plaster the bottom to avoid leaking

When the wall is built at the height to start the weak ring, measure from the level line

1.35 meters	➤	4.6 m <sup>3</sup>	1.44 meters	➤	30 m <sup>3</sup>
1.44 meters	➤	8 m <sup>3</sup>	1.78 meters	➤	50 m <sup>3</sup>
1.29 meters	➤	12 m <sup>3</sup>	2.04 meters	➤	100 m <sup>3</sup>
1.38 meters	➤	16 m <sup>3</sup>			

Clean the inside of the digester chamber and cover with lean mortar the mixture of cement 1 bucket : lime 1/3 bucket : fine sand 2.5 bucket (1 : 1/3 : 2.5 per Volume). Plaster the inside of the wall to 1 cm thick then plaster another layer at 1 cm thick. When cement is setting, use sponge to smooth the wall and to prevent leakage. When the plaster is finished, apply cement to cover the digester chamber floor 5 cm using the mixture cement 1 bucket : coarse sand 2 buckets : gravel 4 buckets (1 : 2 : 4 per Volume), do not cover the center. Leave to dry.

## 5.2 Step 2

### 5.2.1 Why does the soil have to be pressed firmly?

When the concrete face inside the wall is done, fill the outside dome 30 cm high with soil. Press firmly and fill more soil, press firmly again. It is not recommended to fill soil up to the top and press only once because the bottom soil would not be pressed well enough, and the dome will crack. The outside back filling helps to support the high pressure of gas inside the dome. The back filling should be higher than the layers of brickwork and press the soil to the level of the radius stick (Figure 5.9).

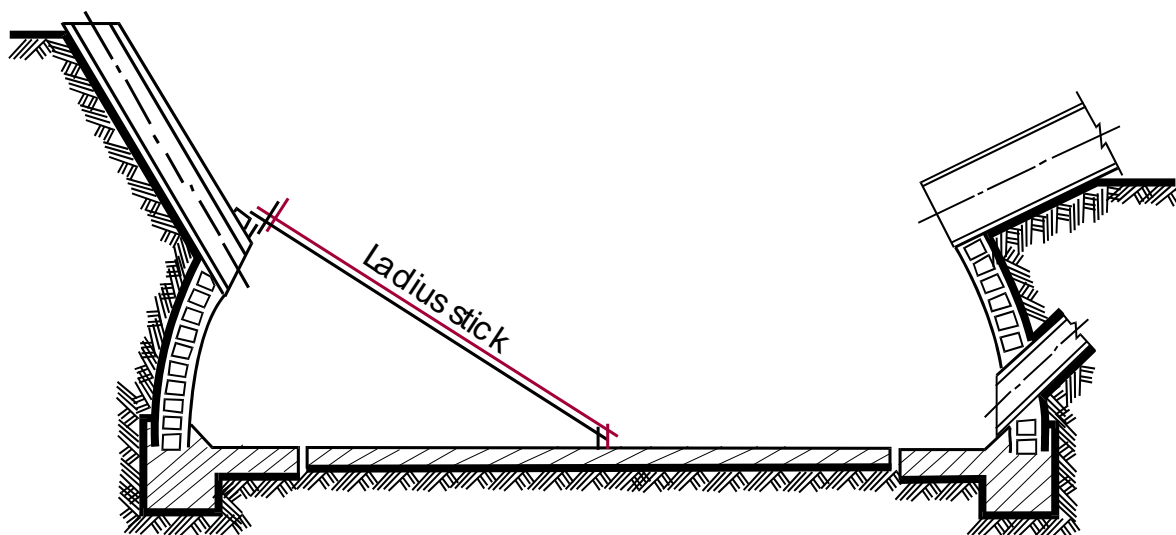

**Figure 5.9 Outside back filling**

**Notice** Face concrete inside the wall before back filling to avoid the problem of having water outside dome.

### 5.2.2 What is a Weak Ring?

A **weak ring** is constructed to separate the bottom wall and the upper part of dome. When the ground is sinking or the wall is cracked, the weak ring will prevent the vertical crack spreading up to the top of the dome. The weak ring is a soft mixture and flexible.

**Mark a circle from the existing wall use radius**

1.42 meters	➤ 4.6 m <sup>3</sup>	2.67 meters	➤ 30 m <sup>3</sup>
1.69 meters	➤ 8 m <sup>3</sup>	3.12 meters	➤ 50 m <sup>3</sup>
1.92 meters	➤ 12 m <sup>3</sup>	3.70 meters	➤ 100 m <sup>3</sup>
2.17 meters	➤ 16 m <sup>3</sup>		

The weak ring is built by placing bricks to form a wall outside the radius. The distance between the wall and weak ring is 1 brick wide. The mixture of cement 1 bucket : lime 3 buckets : fine sand 15 buckets ( 1 : 3 : 15 per Volume ) is required to form a circle over the top of the wall until the thickness is the same as the thickness of the formed brick. Use hard broom to scrape the cement while it is setting then start the next layer of cement until 3 layers are finished. With the same method applied in one day, the thickness of the cement will be approximately 10 cm. Smooth the last layer and leave it to be hardened for 24-48 hours (Figure 5.10).

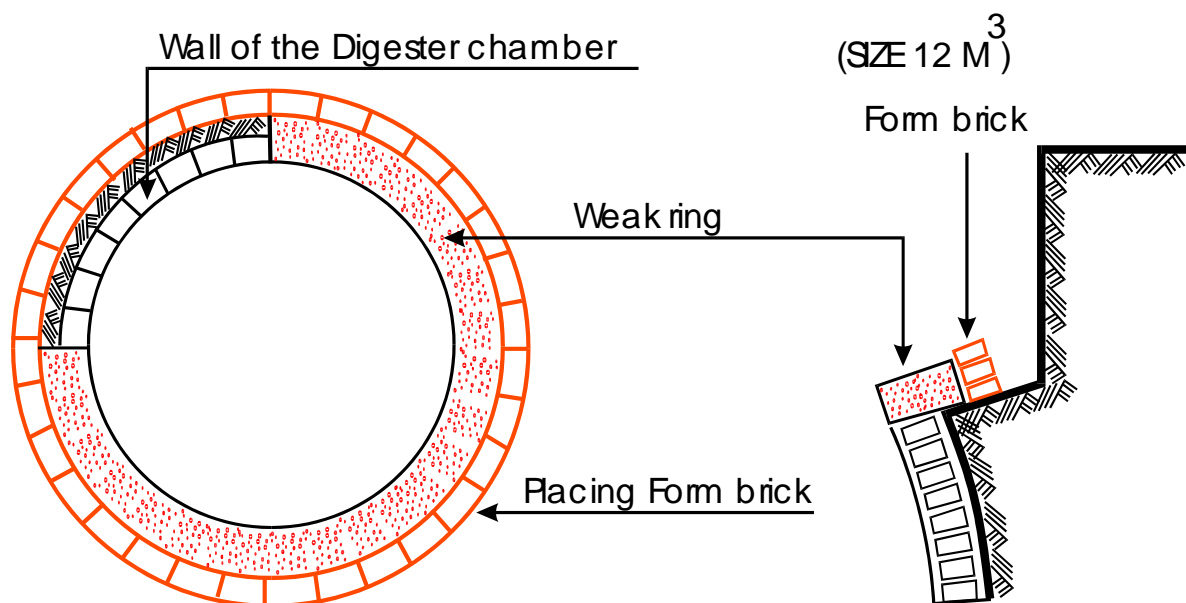

**Figure 5.10 The weakring**

*Notice* Do not use lime replacement



### 5.2.3 What is the Purpose of Expansion Chamber and How it is Built?

The expansion chamber controls the volume of gas in digester chamber and is involved in pushing gas up for usage when the valve is opened., it also drains out manure that has been digester.

To build an expansion chamber, fill the soil up and firmly press. Draw a circle to mark the size of the expansion chamber use radius

1.10 meters	➤	4.6 m <sup>3</sup>	1.50 meters	➤	30 m <sup>3</sup>
1.25 meters	➤	8 m <sup>3</sup>	1.88 meters	➤	50 m <sup>3</sup>
1.30 meters	➤	12 m <sup>3</sup>	2.07 meters	➤	100 m <sup>3</sup>
1.50 meters	➤	16 m <sup>3</sup>			

Mark out where the drainage alley will be excavated then dig a hole to build an expansion chamber according to the drawing. The depth of the chamber is measured from the level line approximately

1.10 meters	➤	4.6 m <sup>3</sup>	1.04 meters	➤	30 m <sup>3</sup>
1.16 meters	➤	8 m <sup>3</sup>	1.05 meters	➤	50 m <sup>3</sup>
1.05 meters	➤	12 m <sup>3</sup>	1.22 meters	➤	100 m <sup>3</sup>
1.10 meters	➤	16 m <sup>3</sup>			

Use plumb to find the center of expansion chamber floor and mark it. Mix the mixture of cement 1 bucket : coarse sand 2 buckets : gravel 4 buckets (1 : 2 : 4 per volume).and apply to built a 5 cm thick floor. The floor is at the same level of the upper edge of the outlet pipe. While the cement is setting, cast the first layer of brickwork use radius to control the line of brickwork (Figure 5.11).

0.90 meters	➤	4.6 m <sup>3</sup>	1.30 meters	➤	30 m <sup>3</sup>
0.95 meters	➤	8 m <sup>3</sup>	1.68 meters	➤	50 m <sup>3</sup>
1.10 meters	➤	12 m <sup>3</sup>	1.87 meters	➤	100 m <sup>3</sup>
1.30 meters	➤	16 m <sup>3</sup>			

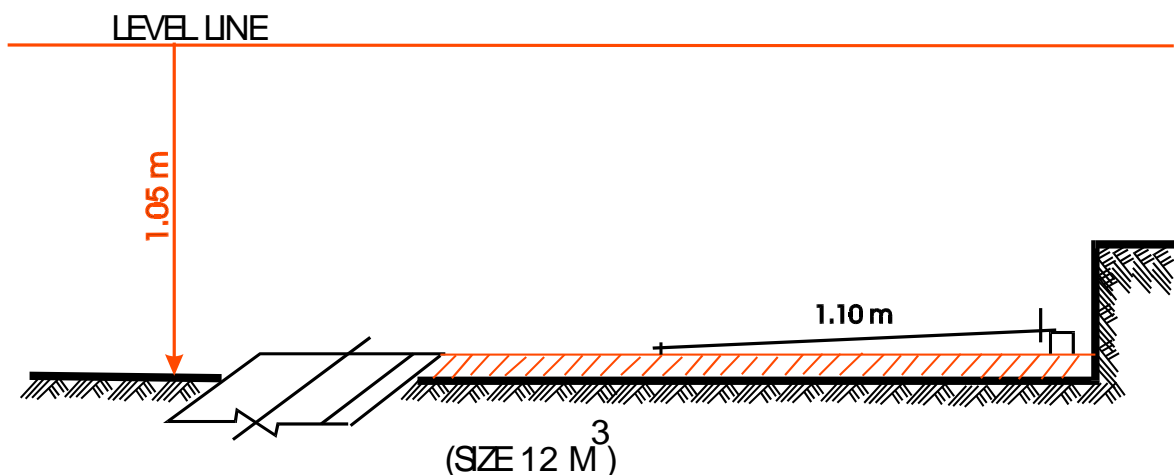
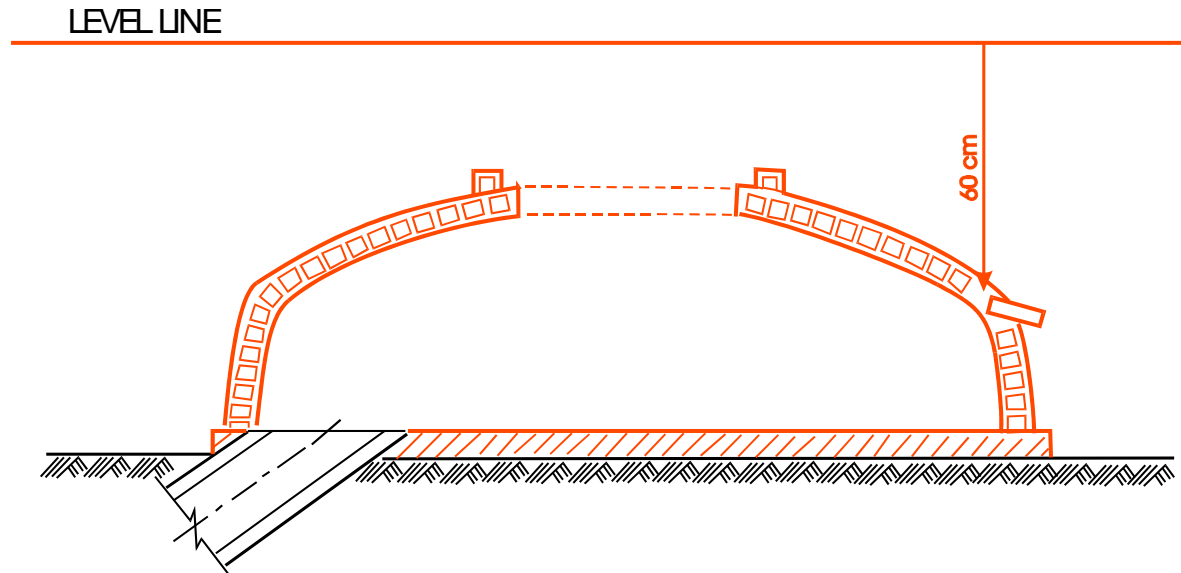

Figure 5.11 Expansion chamber floor

When the first layer is finished, leave it to dry. Soak the bricks prepared for other layers in water to let the cement set better. The mixture of cement 1 buckets : lime 1/3 bucket : coarse sand 2.5 buckets (1 : 1/3 : 2.5 per Volume) is applied to cast a brick wall and use radius stick to maintain the consistency (Figure 5.12).



**Figure 5.12 Cast a brick expansion chamber wall**

When the wall is approximately 60 cm high from the level line, place header bricks where the expansion outlet starts in order to support another layer of bricks. (This outlet width is twice a size of 2 bricks and as high as 3 layers of bricks.) Leave it to be hardened. Mix the mixture of cement 1 bucket : lime 1/3 bucket : fine sand 2.5 buckets (1 : 1/3 : 2.5 per Volume), face the concrete both sides of the wall 1 cm thick and smooth them. When it is dry, continue casting the wall and leave 80cm wide at the top as the outlet. Face the concrete both sides of the wall. Build an outlet channel on the vertical until reaches 90cm from level line. Leave it to be hardened. Face the concrete both sides 1cm thick and smooth the edge (Figure 5.13).

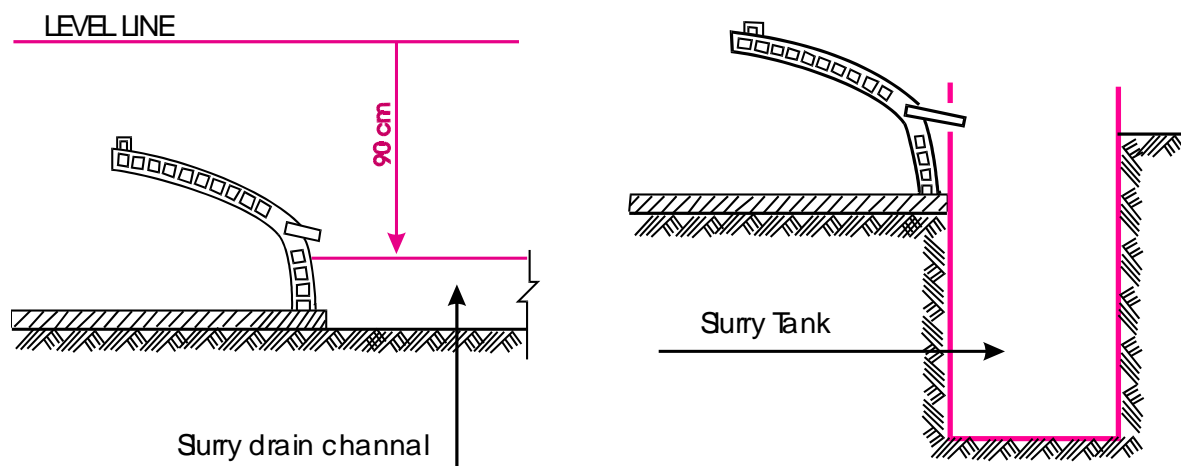

**Figure 5.13 Slurry drainage channel & Slurry tank**

### 5.3 Step 3

### 5.3.1 What is a Dome?

**The dome** collects gas and is located at the top of the digester chamber, separated from the lower wall by weak ring. Build the fixed dome by casting one layer of vertical bricks on top of the weak ring. On each layer, the lower part of brick sticks out 3-5 cm towards the inside of the dome. Build the next layer using the following radius.

1.30 meters	➤	4.6 m <sup>3</sup>	2.55 meters	➤	30 m <sup>3</sup>
1.57 meters	➤	8 m <sup>3</sup>	3.00 meters	➤	50 m <sup>3</sup>
1.80 meters	➤	12 m <sup>3</sup>	3.58 meters	➤	100 m <sup>3</sup>
2.05 meters	➤	16 m <sup>3</sup>			

Cast 5 layers and stop (to build strong ring). When finished continue building until the top of fixed dome is 42 cm wide. Leave it to harden. Pour cement to cover of the digester chamber that had been left earlier (Figure 5.14).

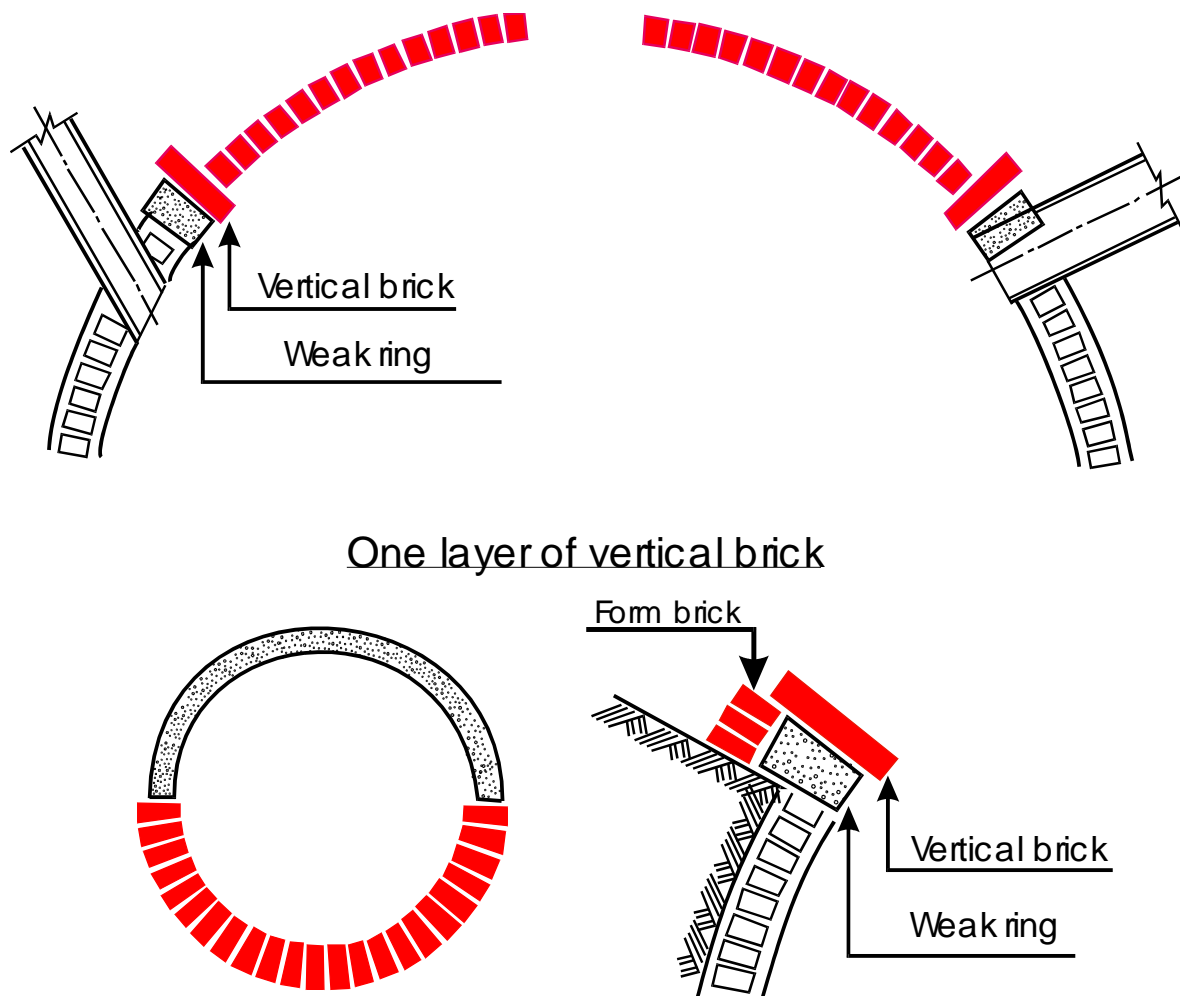

Figure 5.14 The Digester chamber dome

### 5.3.2 Non Crack Dome

Clear the loose cement and clean inside of the fixed dome. Spread lime water over the dome.

**First concrete face** Apply a mixture of cement 1 bucket : lime 1/3 bucket : coarse sand 2.5 buckets (1 : 1/3 : 2.5 per Volume ) to the inside dome to a thickness of 1 cm. Use hard broom to scrape the plaster and leave it for one day.

**Second concrete face** Apply a mixture of cement 1 bucket : lime 1/4 bucket : coarse sand 2.5 buckets (1 : 1/4 : 2.5 per Volume ) to the wall to a thickness of 1 cm thick after lime water is spread. Scrape the wall and leave it to be dry for 1 day.

**Third concrete face** Mix waterproofer with the same mixture of cement mortar. Plaster the dome 1 cm thick including the outlet (manhole). Polish well. Cover the neck of the chamber with sacks for retention (Figure 5.15).

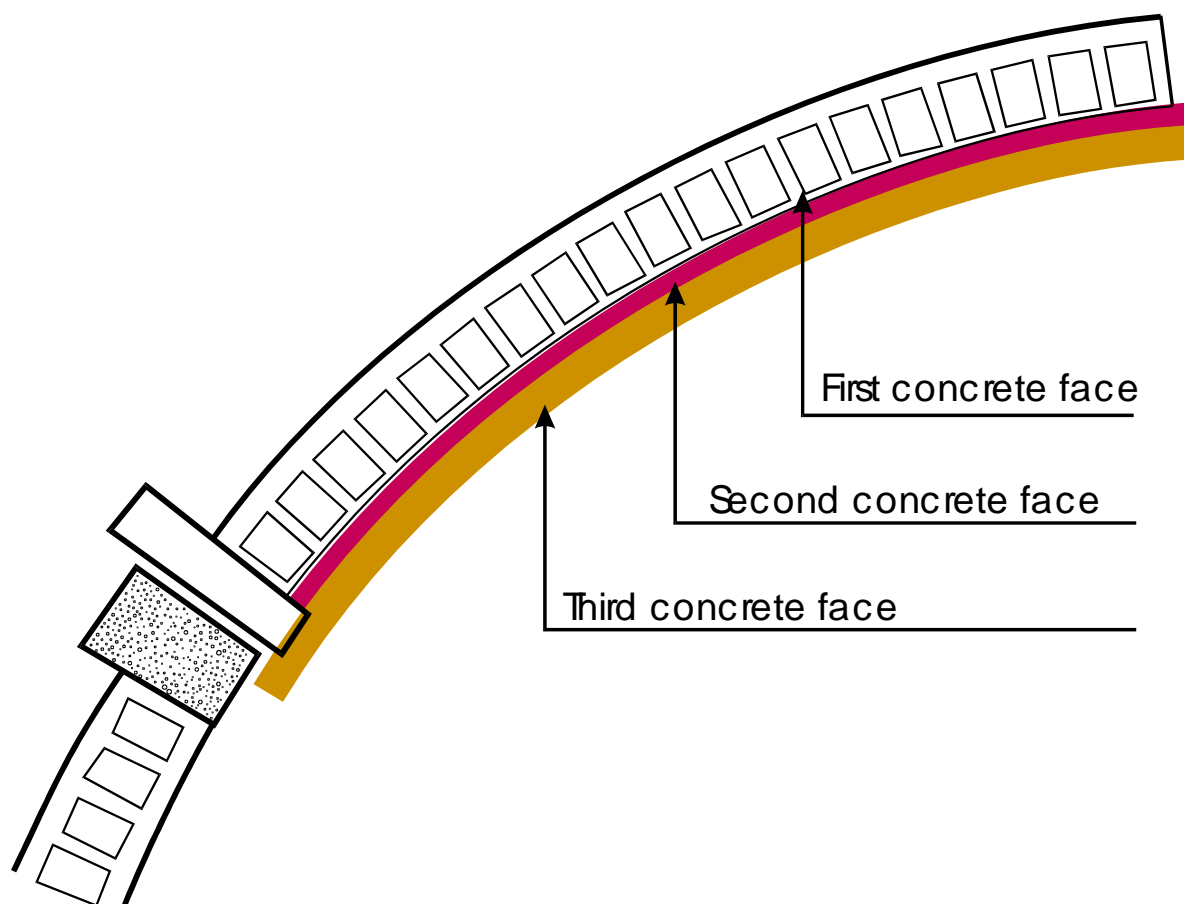

**Figure 5.15 The dome concrete face**

**Notice** Fixed dome is where gas is collected. Workers must follow the instruction strictly. Do not rush to face the concrete in one day, it cannot prevent the crack.

### 5.3.3 Strong Ring is the Beam of Fixed Dome

The upper part of fixed dome is also very important. The strength of fixed dome is required by the mixture of cement 1 bucket : coarse sand 2 buckets : gravel 4 buckets (1 : 2 : 4 per Volume ). Before the cement is poured, remove the brick of the weak ring. Chip the soil under weak ring until reaches the first brick and strike the loosen cement out. Clean the outside wall, spread weak ring and 3 layers above with lime water. Pour cement to cover the vertical bricks in a shape of turtle back. Leave it to dry for one night (Figure 5.16).

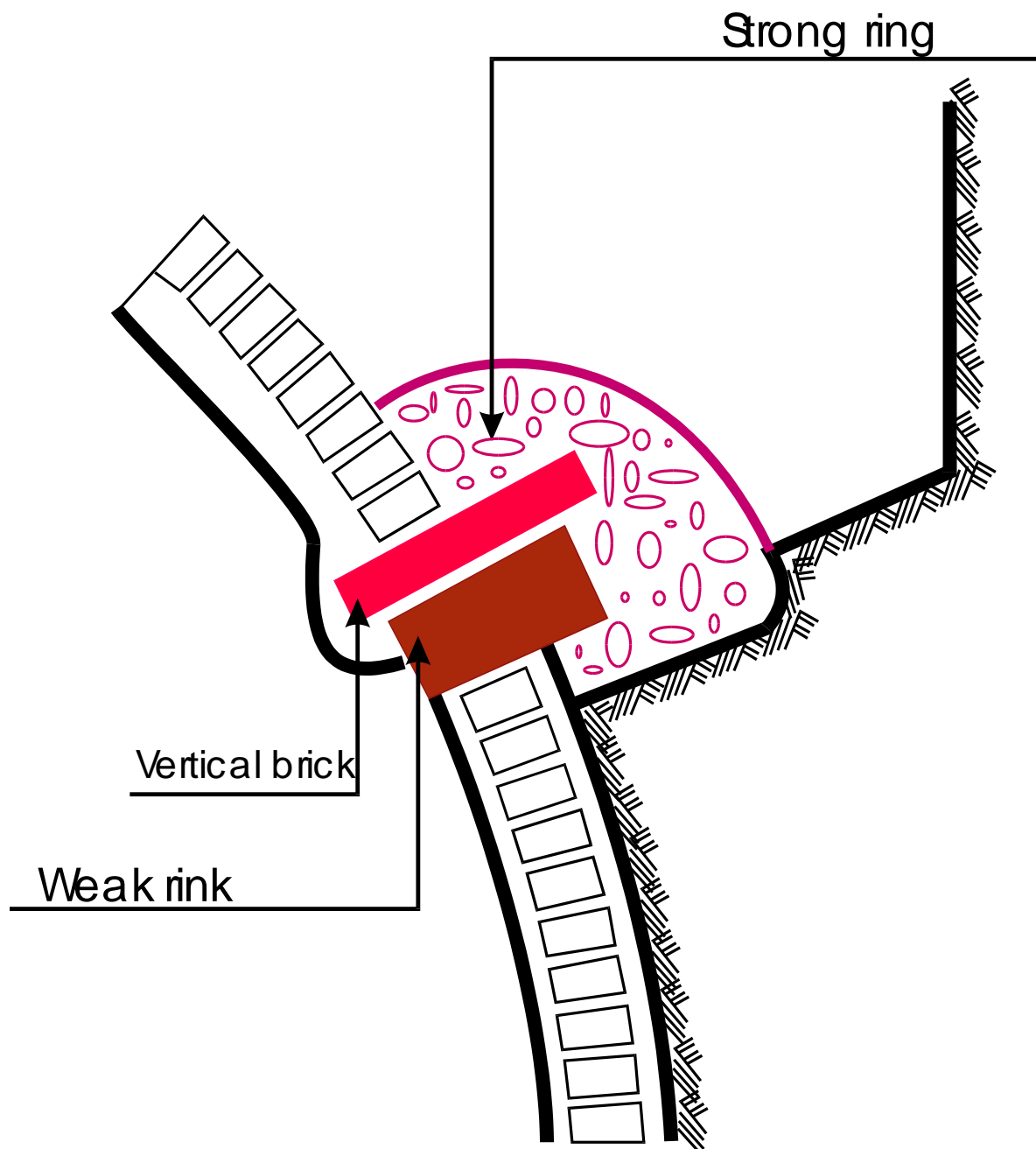

Figure 5.16 The strong ring

### 5.3.4 Why is the Neck of the Chamber Required?

The neck of the chamber is built to support the lid. Place a 70-80 cm diameter concrete ring on top of the open chamber. Adjust this 42cm hole until it is in the middle of the ring. Use water adjusting level to balance the vertical level. Use nail to mark the circle and remove the ring. Build up an edge with cement mortar and replace the ring exactly at the marked spot. Place steel mould to shape the inner wall. Put bricks inside the mould for ballast to stop the mould from moving. Coat oil to the outer mould to facilitate the removal of the mould (Figure 5.17). Clean the floor and spread the floor and the neck of the chamber with lime water. Use the mixture of cement 3 buckets : coarse sand 6 buckets : gravel 9 buckets (3 : 6 : 9 per Volume) to fill the gap until the height is 10 cm below the edge of the mould. Poke well to get rid of air bubbles. Place a wedge plugged with banana stem, (Figure 5.19) 4 cm measured from the top edge of the mould to the back of the wedge (Figure 5.18). Mark the position of wedges on the cement edged when the mould is removed, it will be easy to find the position later. There are 3 pieces of the wedges rested in triangle position with the end of each wedge 48 cm apart from each other (Figure 5.20). The gas pipe lies directly opposite one of the wedges. . Pour the rest of the cement to fill up to the top of the neck without poking because it may cause the wedges to move. Smooth the surface and leave it to dry for one day.

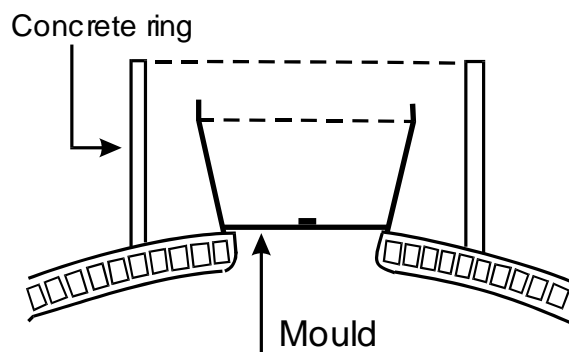

Figure 5.17 The neck

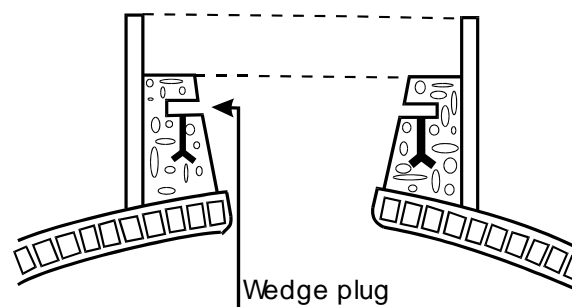

Figure 5.18 Position of the wedge plug

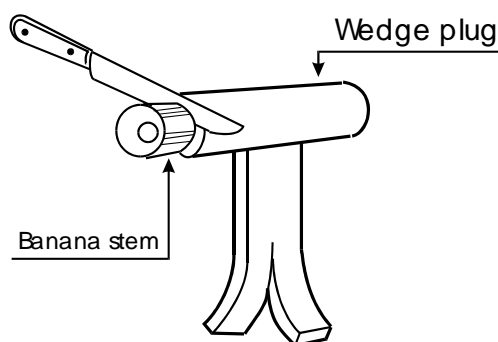

Figure 5.19 wedge plugged with banana stem

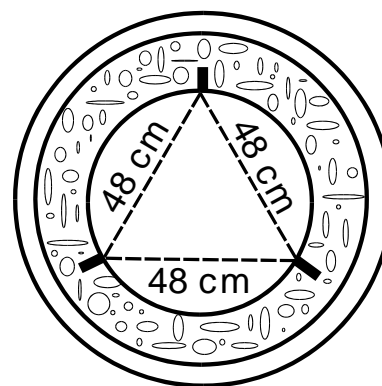
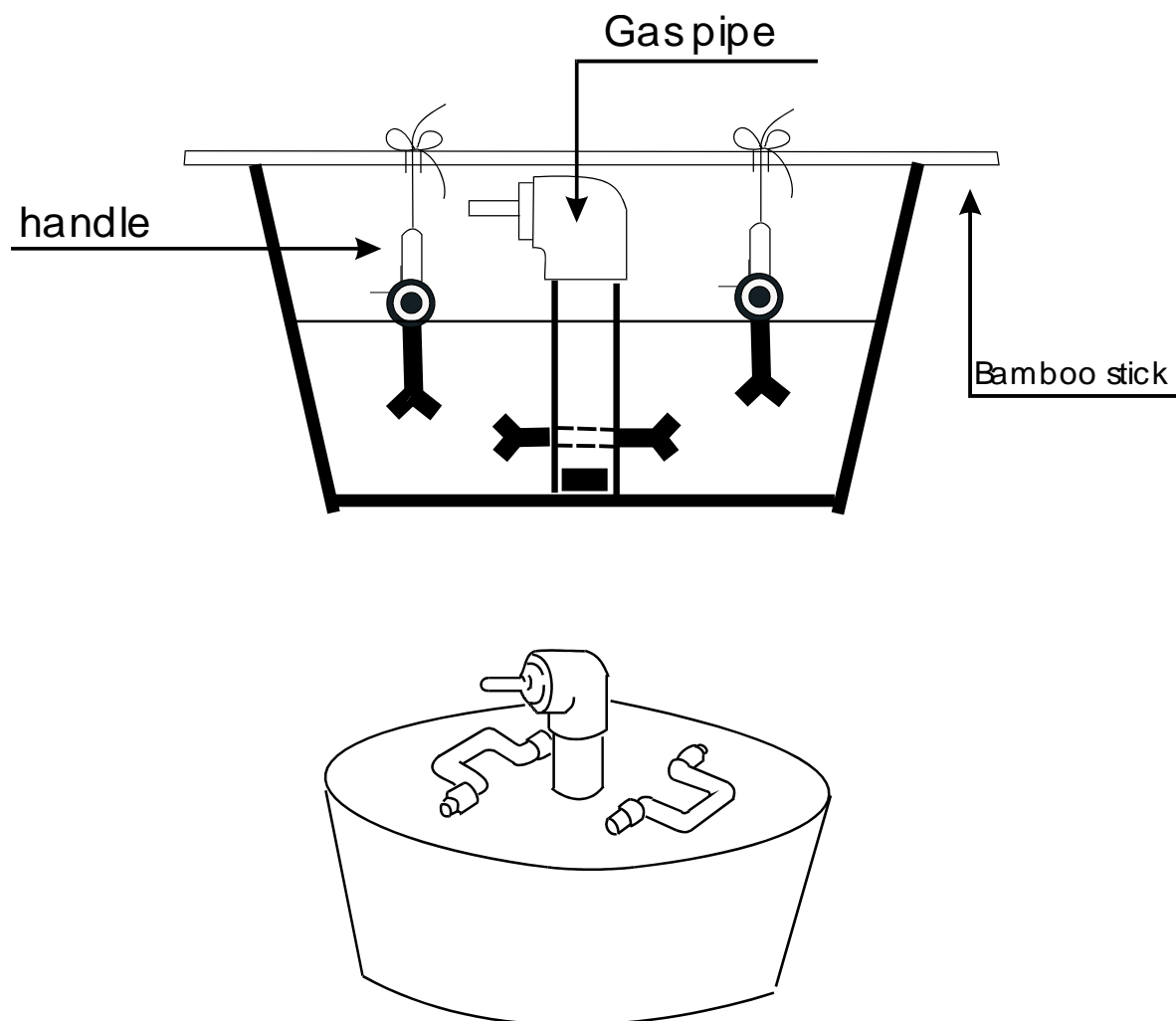

Figure 5.20 Triangle position

### 5.3.5 How to Mould the Lid?

Before moulding the lid, the steel mould and gas pipe must be cleaned with wire brush. Coat the inside with oil and set the gas pipe together with 90° (1.5 inch) joint. Pour the mixture of cement 2 bucket : coarse sand 4 bucket (1 : 2 per Volume) into the mould until a depth of 15 cm is reached. Use a hammer strike the outside mould to get rid of air bubbles. Secure 2 handles by tying to a bamboo stick laid across top of the mould. Smooth the surface and leave it to harden. Use a sack to cover the mould to avoid any cracks. After 1-2 days remove the mould and leave the lid in water until it is being used (Figure 5.21).



**Figure 5.21 The lid**

### 5.3.6 The Outside Dome Plaster

Clean the outer wall including the strong ring and spread with lime water. The mixture of cement 1 bucket : lime 1/3 bucket : coarse sand 2.5 buckets : (1 : 1/3 : 2.5 per Volume) is required to plaster the outer wall until the thickness of 3 cm is reached. Polish and leave it to be hardened (Figure 5.22). When the cement is completely dry, cover it with sacks and apply water 3 times a day to maintain the retention. After that fill the back with soil. The expansion chamber and the digester chamber must be covered well under the soil and only the necks are left free to avoid any cracks and to let the weight of soil support against the dome. Vegetables or grass can be planted on the top to prevent eroding or provide a good sight.

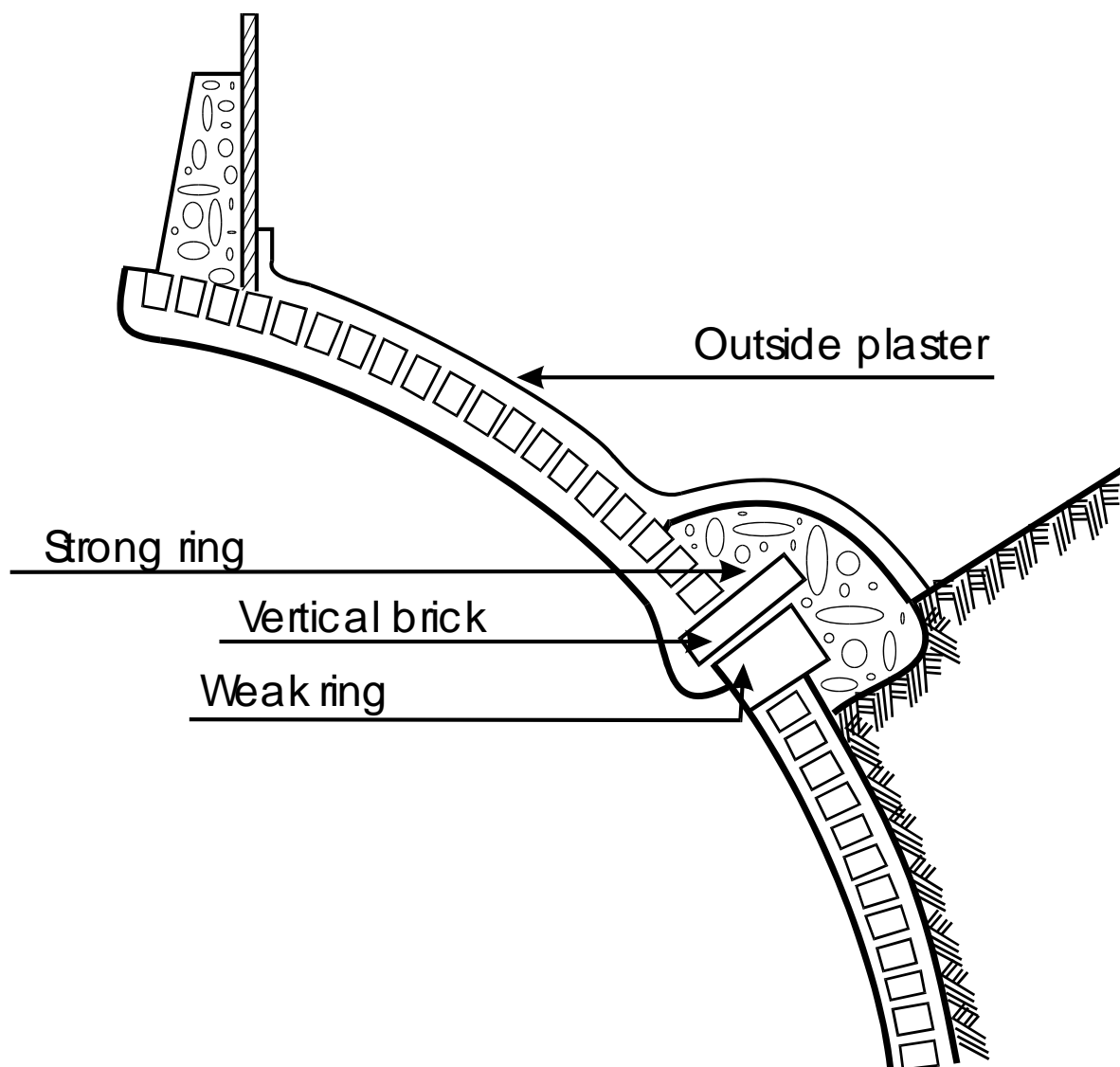

**Figure 5.22** The outer plaster cement



## 5.4 Step 4

### 5.4.1 Gas Pipe Installation

It is one of the most important Steps of the construction. If the pipes are badly connected or if there is any leakage, the volume of gas will decrease. Some farmers will blame it on the construction of the chambers

### 5.4.2 The Piping System

1. **Excavating the channel.** Set the level of the channel slight slope from the valve at the outlet to the lowest point at least 20 cm deep and 20 cm wide. From the lowest point dig a trap water pit sizes 30 cm x 50 cm x 50 cm. Form a brick wall, fill the floor with cement and face the concrete to the inner wall with cement added waterproofer.
2. **Gas pipe.** If the piping distance is within 20 meters use 6/8 inch PVC pipe. The 1 inch pipe is suitable for the distance further than 20 meters.
3. **Checking the pipe.** The pipe is checked by closing one end with a palm and letting a person blow through the other end of the pipe. Blow for 1 minute, if the pressure is still stable, it indicates the sufficiency. If the pressure is reducing, the pipe is leaking, change new pipe.
4. **Clean the pipe and joint.** Use sand paper No.100 to scrape the end of pipe and inside the joint then clean well.
5. **Gluing.** Apply glue onto the parts that will be connected both the end of the pipe and inside the joint. Put them together and press with palms for 30 seconds then release.
6. **Water trap.** Apply T-joint 15-20 cm downward into water trap pit and install the valve at the end of the joint (Figure 5.23).
7. **Piping system.** Line the pipe to an area where the gas will be used. Install a gas valve and steel plate collar over the PVC pipe to connect to gas equipment. The pipe must be well covered underground to avoid cracks caused by animal or vehicles.

Figure 5.23 Water trap

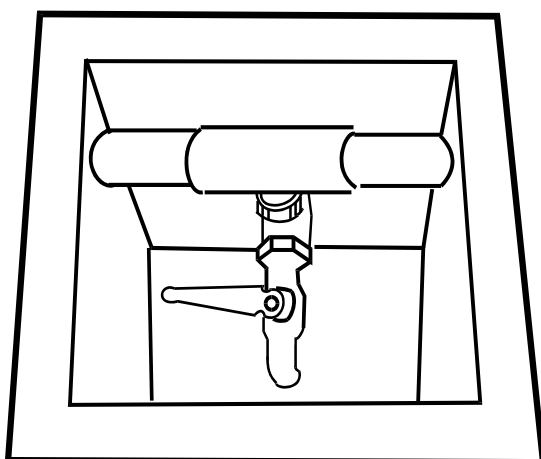

Water Trap Pond

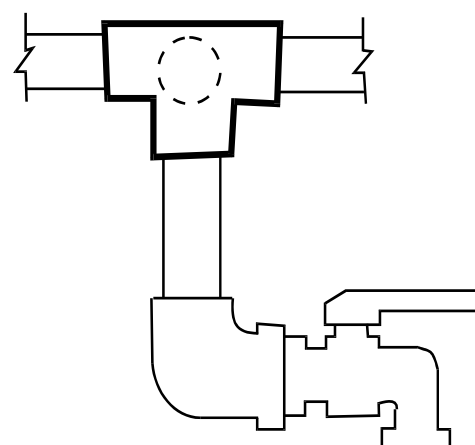

Water Trap

*Notice* To connect to screw pipe use tape to wind threads before connection. Do not wind too tight, the pipe may break. The locations where valve should be in stalled are the outlet of digester chamber, the place where gas the equipment will be installed and manometer.

### 5.4.3 Closing the Lid

Use well kneaded clay (without any stones) to plaster around the edge of the manhole or the outlet to a thickness of 1cm. Plaster the lid 0.5 thick. Remove the banana stems used to clog the wedge. Put the lid to cover the edge of the outlet slowly and check the level. Press hard using body weight. Insert pegs to secure under the wedges and fill with water until they are covered. Before closing the lid, plan where the gas pipe is to be connected (Figure 5.24).

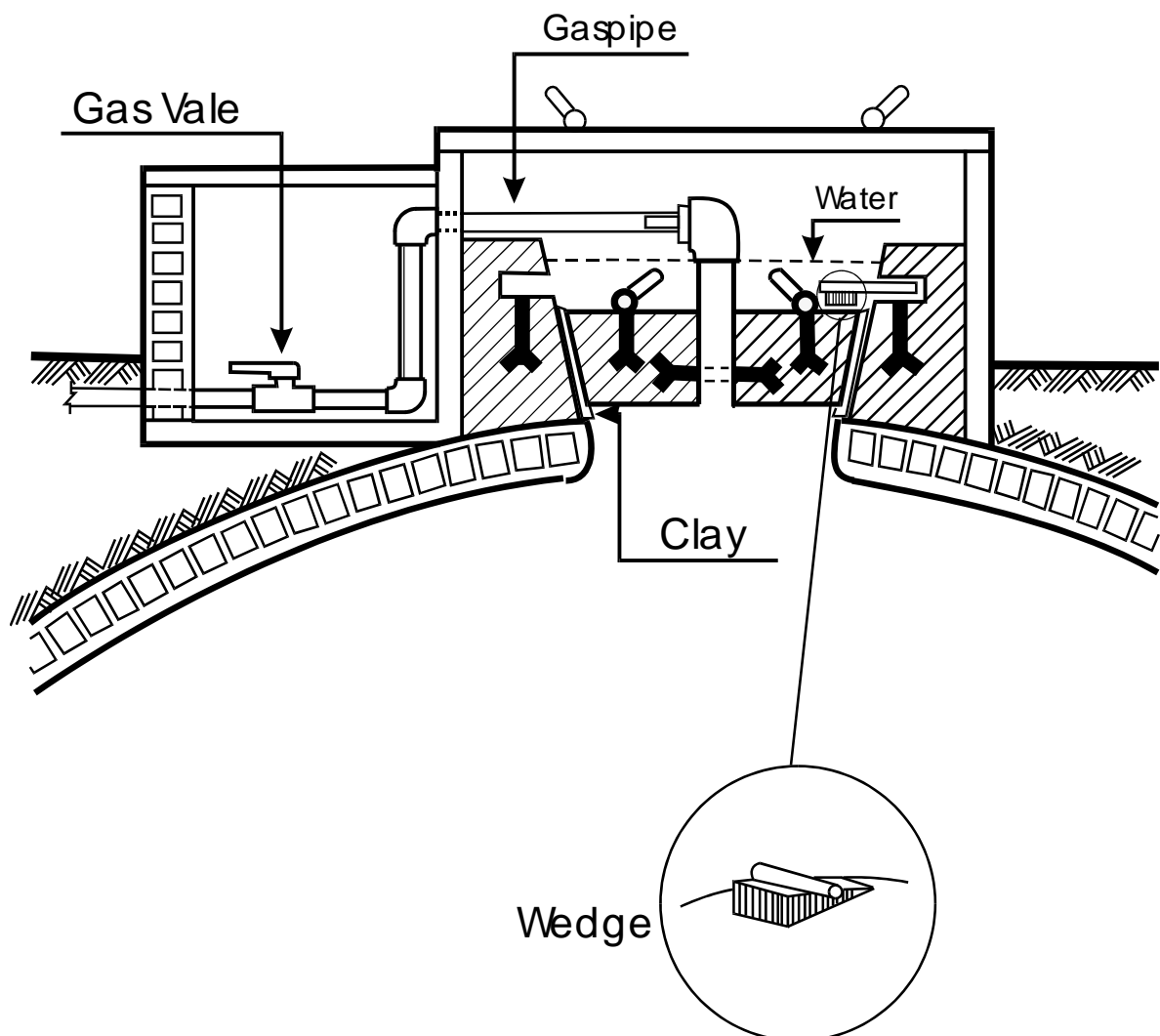

Figure 5.24 Closing the lid

#### 5.4.4 Why the Chamber has to be Tested?

The most important process of constructing the bio-gas plant is to test the gas chamber and gas pipe. If there is any crack, gas can not be stored. Before filling animal excrement, the leakage must be tested.

##### **Testing unit**

*Mano-meter* is connected to the gas pipe at the outlet of the digester chamber. Fill water into either the inlet pipe or expansion chamber until the mono meter can be read 80 cm. (40 x 2) and leave it for 12 hours.

If the pressure reduces by less than 10 cm (5 x 2), the gas chamber is in good condition. If the pressure reduces more than 10 cm, check the possible sites where water is seeping, for example at the bottom of digester chamber, the bottom of the expansion chamber or leakage of air through fixed dome. Repair cracks and leaks and test again until air is not leaking (Figure 5.25).

*Testing gas pipe.* Close valves of the digester chamber and the water trap. Open kitchen valve and blow into gas pipe until the pressure is at 80 cm. Close valve in the kitchen leave it for 1 hour. If the pressure reduces, there is leakage. Check every joints and T joints by using soap water. The bubbles will indicate the leakage. Change a new joint. When the gas chamber is tested and there is no leakage, fill the animal excrement without release water in the chamber.

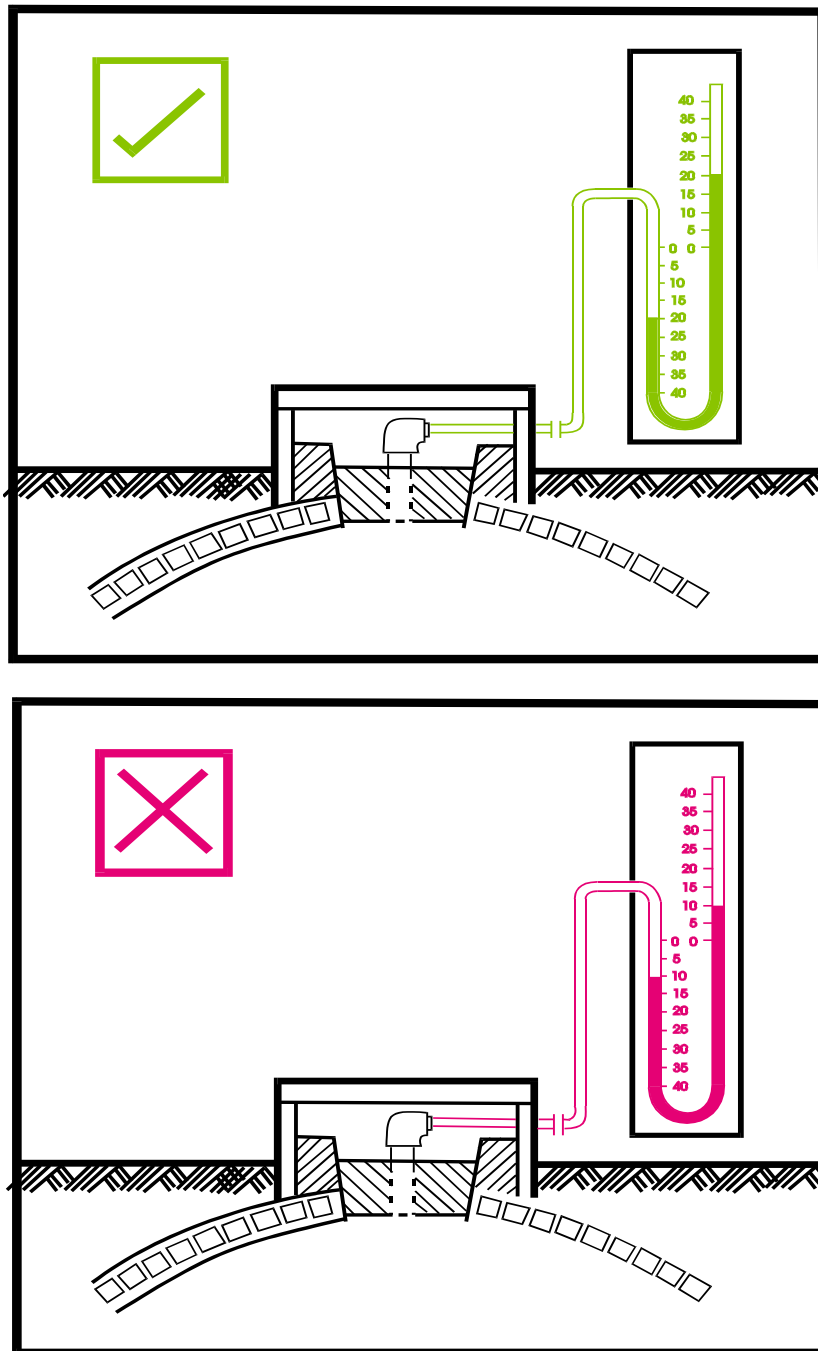

Figure 5.25 Manometer Testing

**Notice** If the gas pipe is already connected to the digester chamber, the chamber and pipe can be tested together by installing the mono meter. Close kitchen's valve and water trap valve then open valve at the digester chamber. Testing according to the above suggestion.

## Chapter 6

### Additional Information in Reactor Construction

#### 6.1 Where to Fill in Animal Excrement?

The drainage alley must be built connected to the enclosure. The floor should be slightly arched polished. The excrement will flow easily and no residue will be left. Connect the alley to the inlet of the mixing chamber. There is a gate built at the mixing chamber for mixing the excrement and let it flow into the chamber (Figure 6.1).

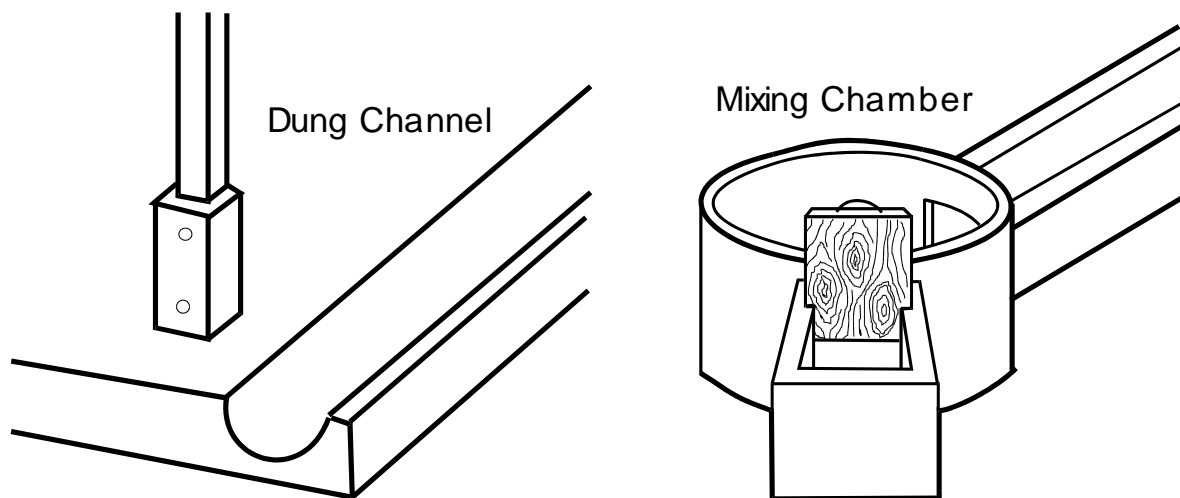

Figure 6.1 Dung channel & mixing chamber

#### 6.2 Lids

Lids are required to prevent animal and rain water to fall in and also to keep it tidy. The lids are for

- ✱ Digester chamber
- ✱ Pit where the valve is installed for the digester chamber.
- ✱ Expansion chamber
- ✱ Water trap pit
- ✱ Storage tank

### 6.3 Storage Tank

Storage tank collects overflow manure from the expansion chamber. Manure in the storage tank can be used as fertilizer to improve soil by pouring over agricultural fields, fruit plantations grass. It prevents the manure from overflowing to the outside ground (Figure 6.2).

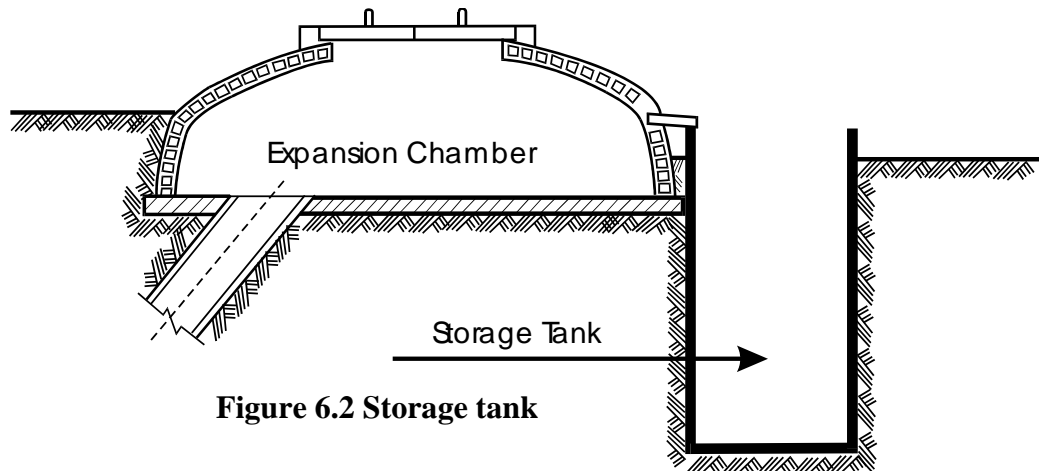

Figure 6.2 Storage tank

### 6.4 Addition of the First Animal Excrement

After the chamber is tested, animal excrement can be filled into the mixing chamber without releasing water. When the excrement is added, use the water from the expansion chamber to mix and stir until it become liquid slurry. Release the testing pressure by opening valve at the water trap. Let the air vent out until it is empty then close the valve. The manure will flow into the digester chamber. It is not recommended to fill up the top at one time so as to avoid the slow production of gas or decomposing. It should be added portion by portion until full. The first adding takes about 7 days as follows :

#### 6.4.1 The first filling (first 7 days), use cow or buffalo excrement

	4.6 m <sup>3</sup>	8 m <sup>3</sup>	12 m <sup>3</sup>	16 m <sup>3</sup>	100 m <sup>3</sup> pig
Cow or buffalo excrement	330 liters	600 liters	800 liters	1200 liters	4,000 liters
Water	330 liters	600 liters	800 liters	1200 liters	8,000 liters

**Notice** If cow or buffalo excrement is not available, pig excrement is accepted by using half of the suggested quantity. After 2 weeks, add normally according to the manual.

#### 6.4.2 Next filling, after the first 7 days, add excrement daily

	4.6 m <sup>3</sup>	8 m <sup>3</sup>	12 m <sup>3</sup>	16 m <sup>3</sup>	100m <sup>3</sup>
Cow or buffalo excrement	38 liters	70 liters	100 liters	140 liters	833 liters
Water	38 liters	70 liters	100 liters	140 liters	833 liters
Pig excrement	25 liters	50 liters	70 liters	90 liters	660 liters
Water	50 liters	100 liters	140 liters	180 liters	1,320 liters

Gas will be produced within 2-3 days.

**Notice** Do not fill more than suggested because gas will cease. If filling too little, gas will be slowly produced.







## 6.6 Equipment Used in Construction

Description	4.6m <sup>3</sup>	8 m <sup>3</sup>	12 m <sup>3</sup>	16 m <sup>3</sup>
Grounded rocks or gravel ½ inch	2 m <sup>3</sup>	2 m <sup>3</sup>	3 m <sup>3</sup>	4 m <sup>3</sup>
Coarse sand	2 m <sup>3</sup>	3 m <sup>3</sup>	3 m <sup>3</sup>	4 m <sup>3</sup>
Fine sand	1 m <sup>3</sup>	2 m <sup>3</sup>	3 m <sup>3</sup>	4 m <sup>3</sup>
Brick size 7x17 cm tin 4.5 cm.	2,500 pcs	3,000 pcs.	4,200 pcs.	5,000pcs
Cement	22 bags	25 bags	35 bags	40 bags
Waterproofer	1 tin	1 tin	1 tin	1 tin
Lime	6 bags	8 bags	10 bags	15 bags
Lime replace	1 tin	1 tin	1 tin	1 tin
Concrete pipe diameter 10-12 inch	1 piece	1 piece	1 piece	1 piece
Concrete ring diameter 70 cm	2 pieces	2 pieces	2 pieces	2 pieces
Concrete ring diameter 80 cm (Storage tank)	2 pieces	3 pieces	3 pieces	3 pieces
PVC pipe diameter 6”(inlet and lower outlet )	1piece	1 piece	1 piece	1 piece
Handle set		1 set	1 set	1 set
Mono-meter		1 set	1 set	1 set

## Equipment Used in Construction (continued)

Description	30m <sup>3</sup>	50m <sup>3</sup>	100m <sup>3</sup>
Grounded rocks or gravel ½ inch	6 m <sup>3</sup>	3m <sup>3</sup>	10 m <sup>3</sup>
Coarse sand	6 m <sup>3</sup>	12 m <sup>3</sup>	15 m <sup>3</sup>
Fine sand	6 m <sup>3</sup>	6 m <sup>3</sup>	10 m <sup>3</sup>
Brick size 7x17 cm tin 4.5 cm.	6,500 pcs	13,000pcs	18,000pcs
Cement	70 bags	120 bags	170 bags
Waterproofer	1 tin	1 tin	2 tin
Lime	15 bags	20 bags	30 bags
Lime replace	2 tin	3 tin	4 tin
PVC pipe diameter 10-12 inch	2 piece	3 piece	3 piece
Concrete ring diameter 70 cm	2 piece	2 piece	2 piece
Concrete ring diameter 80 cm (Storage tank)	3 piece	3 piece	3 piece
Handle set	1 set	1 set	1 set
Mono-meter	1 set	1 set	1 set

### 6.7 Summary of Ratio of Cement Mixture for Construction

Step of construction	Cement bucket	Water proofer	Lime bucket	Sand bucket	Gravel bucket
Base of digester and expansion chamber	1	-	-	2	4
Chamber walls	1	-	1/3	2.5	-
Back filling	1	-	-	2	4
Outer wall mortar	1	-	1/3	2.5	-
Weak ring	1	-	3	1.5	-
Strong ring	1	-	-	2	4
Mortar for Digester chamber bottom wall	1	-	1/3	2.5	-
Mortar for inner wall of digester dome – first layer	1	-	1/3	2.5	-
Mortar for inner wall of digester dome – second layer	1	-	1/4	2.5	-
Mortar for inner wall of digester dome – third layer	1	with	1/4	2.5	-
Polish mortar	1	with	-	-	-
Digester chamber neck	1	-	-	2	4
Digester chamber lid	2	-	-	4	-
Mortar for water trap pit	1	With	1/3	2.5	-

#### **Notice**

- Follow the instruction of lime replace on the label strictly
- 1/3 means in one bucket, divide the material into 3 parts and use only one part
- 1/4 means in one bucket, divide the material into 4 parts and use only one part

#### **Caution**

Do not use lime replacement when constructing the weak ring

### 6.8 Materials Used to Connect Gas Pipe per one Chamber

Description	Quantity	Remarks
1. 90° Iron joint	1 pc.	Use with lid
2. Iron joint diameter 1.5 “ reduce to 6/8 “	1 pc.	Use with lid
3. Hose holder 6/8“	2 pcs.	Use with lid
4. Water valve 6/8”	1 pc.	Use with outlet
5. Water valve 4/8 “	1 pc.	Use before connecting with stove
6. Water tap 4/8”	1 pc.	Use with water trap
7. Hose joint (brass)4/8” reduce to 3/8”	2 pcs.	Use with stove
8. Joint 6/8”	1 pc.	Use with tap
9. Joint 6/8”	2 pcs.	Use at the neck of the chamber
10. Joint 4/8” inner screw	2 pcs.	Use with tap
11. Joint 4/8” outer screw	2 pcs.	
12. T joint 6/8” reduce to 4/8”	1 pc.	To the kitchen
13. T joint 4/8 inner screw	1 pc.	Use with manometer pipe
14. Thick hose diameter 1”	1 ft	Use with the neck of the chamber
15. Gas hose	1 meter	Use with gas stove
16. Straight joint 6/8 reduce to 4/8	1 pc.	Use in the kitchen
17. Tape	2 roll	
18. Hose clamp 1”	2 pcs.	
19. Hose clamp 4/8”	3 pcs.	
20. PVC pip 4/8”	1 pc.	
21. PVC pipe 6/8”	Real quantity used	
22. Straight joint 6/8” and 4/8”	Real quantity used	
23. 90° joint 6/8” and 4/8”	Real quantity used	
24. Glue used with PVC pipe and clamp	Real quantity used	
25. Stove or equipment used with gas	Real quantity used	
26. Mono-meter	1 set	

*Notice* Use the same brand of PVC pipes, joints and glue.

## 6.9 Sand Bed Filter

Excavated soil 4 x 2.40 m x 95 cm deep from reference line to build a sand bed filter of sizes 8-16 m<sup>3</sup>. Pour cement to form a 6 cm high beam. Lay a course of bricks divided into 3 beds of size 1.20 x 2.20 m. On the length sides of each wall lay one brick horizontal to form an edge to wipe the manure. On the back of each brick is 70 cm lower than the reference line. Lay another course of bricks. Build a drainage alley connected between the sand bed filter and the outlet of the expansion chamber. This alley is parallel to the filter. The width of the alley is 20 cm and 2 cm deep from the outlet of the expansion chamber.

Make a small hole in the middle of each bed at the end of the sand bed filter. Insert a 2 inches PVC joint to let the filtered slurry flow out. Build an alley to connect to the end of the sand bed filter to let filtered water to drain out or to flow into the storage tank. When finished, face the concrete both inside and outside. Pour cement to cover each floor of the beds with 3 cm slope from the side into the middle and from the start of the sand bed filter to the end (Figure 6.3, 6.4).

Sand bed filter consists

- First layer* 10 cm thick of gravel or grounded rocks size ½ inch
- Second layer* Nylon mesh

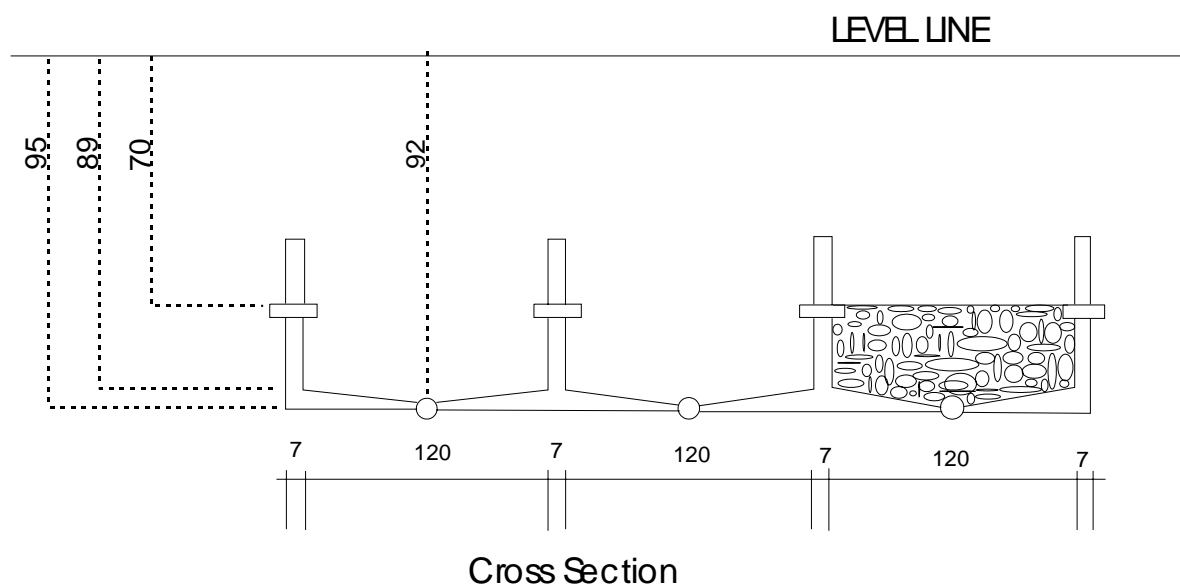

**Figure 6.3 Sand bed filter**

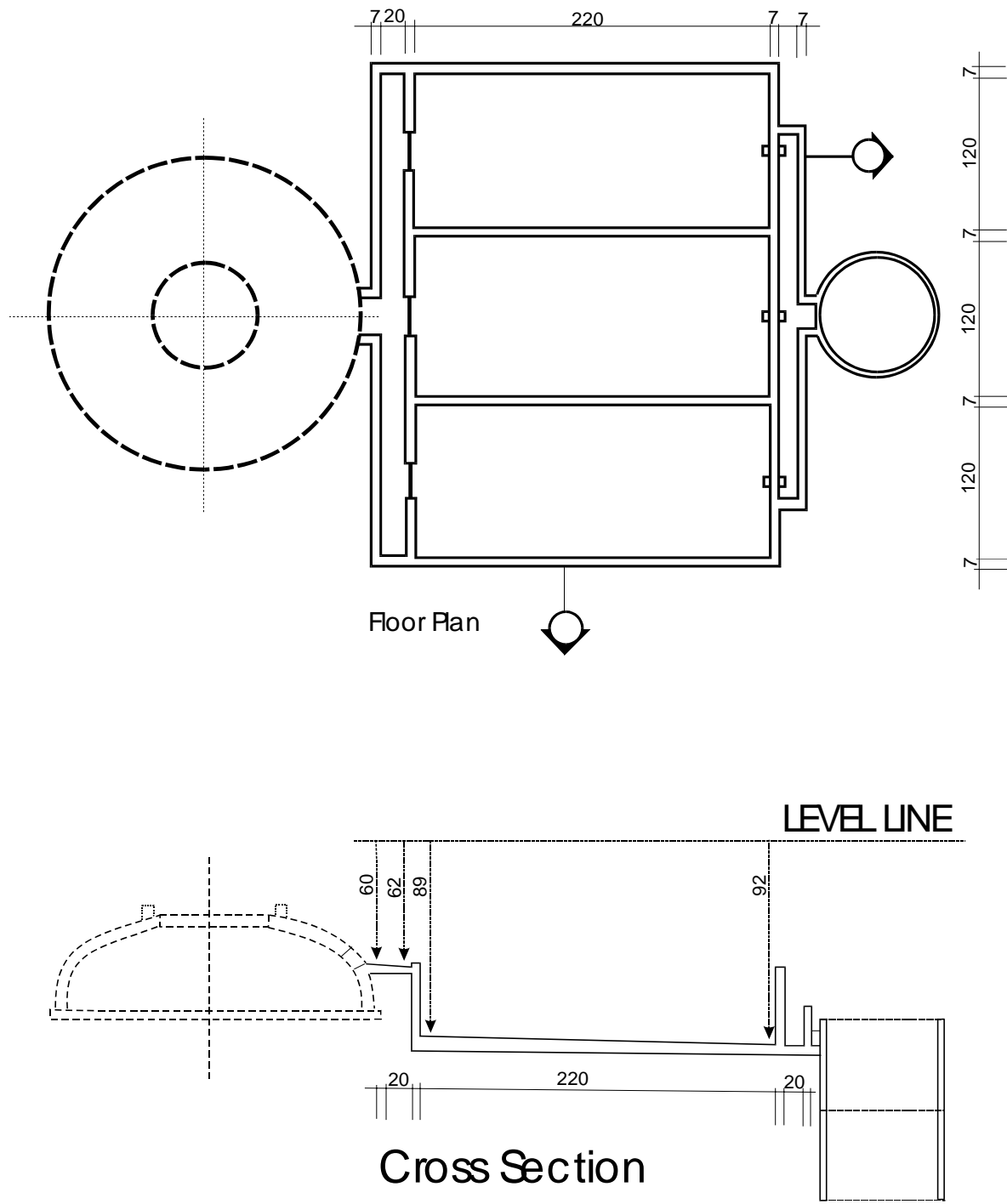
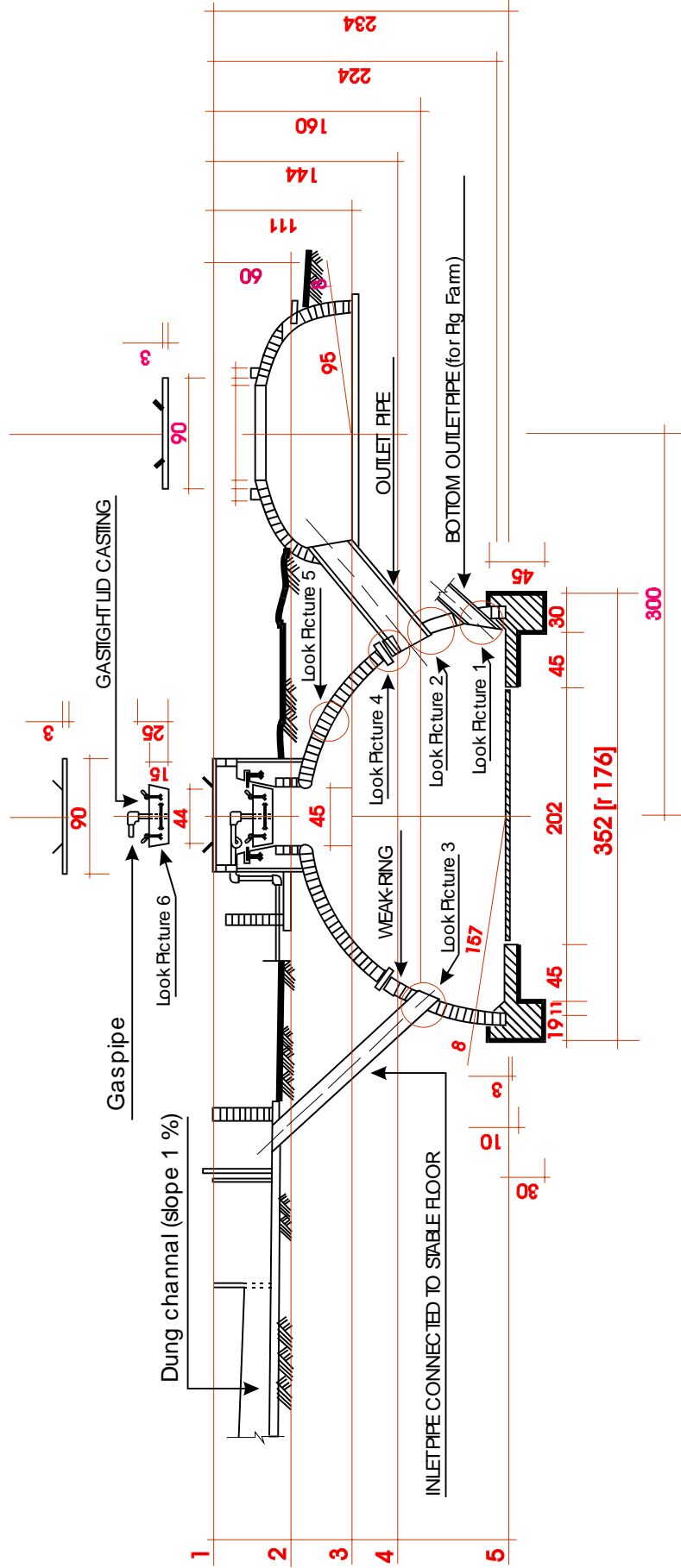
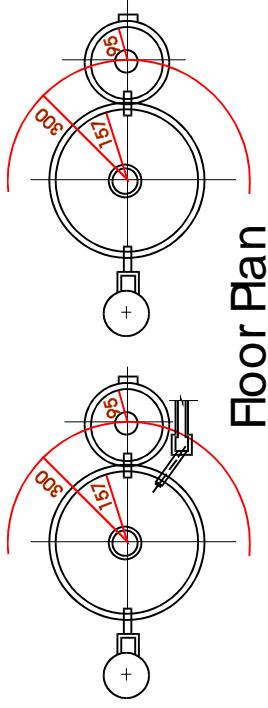

**Figure 6.4 Sand bed filter**

REMARK

- ① HORIZONTAL REFERENCE LINE 0 CM.
- ② HIGHEST SLURRY LEVEL 60 CM.
- ③ BOTTOM OF EXPANSION CHAMBER 111 CM.
- ④ LOWEST SLURRY LEVEL, WEAK RING 144 CM.
- ⑤ BOTTOM LINE 234 CM.

Size 8 m<sup>3</sup>





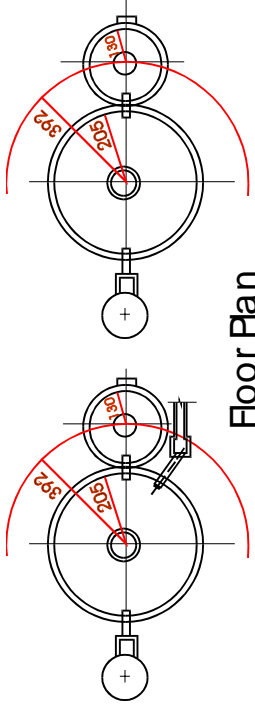

Floor Plan

- REMARK
- ① HORIZONTAL REFERENCE LINE 0 CM.
  - ② HIGHEST SLURRY LEVEL 60 CM.
  - ③ BOTTOM OF EXPANSION CHAMBER 111 CM.
  - ④ LOWEST SLURRY LEVEL, WEAK RING 144 CM.
  - ⑤ BOTTOM LINE 234 CM.
- ALL DIMENSION IS CENTIMETER

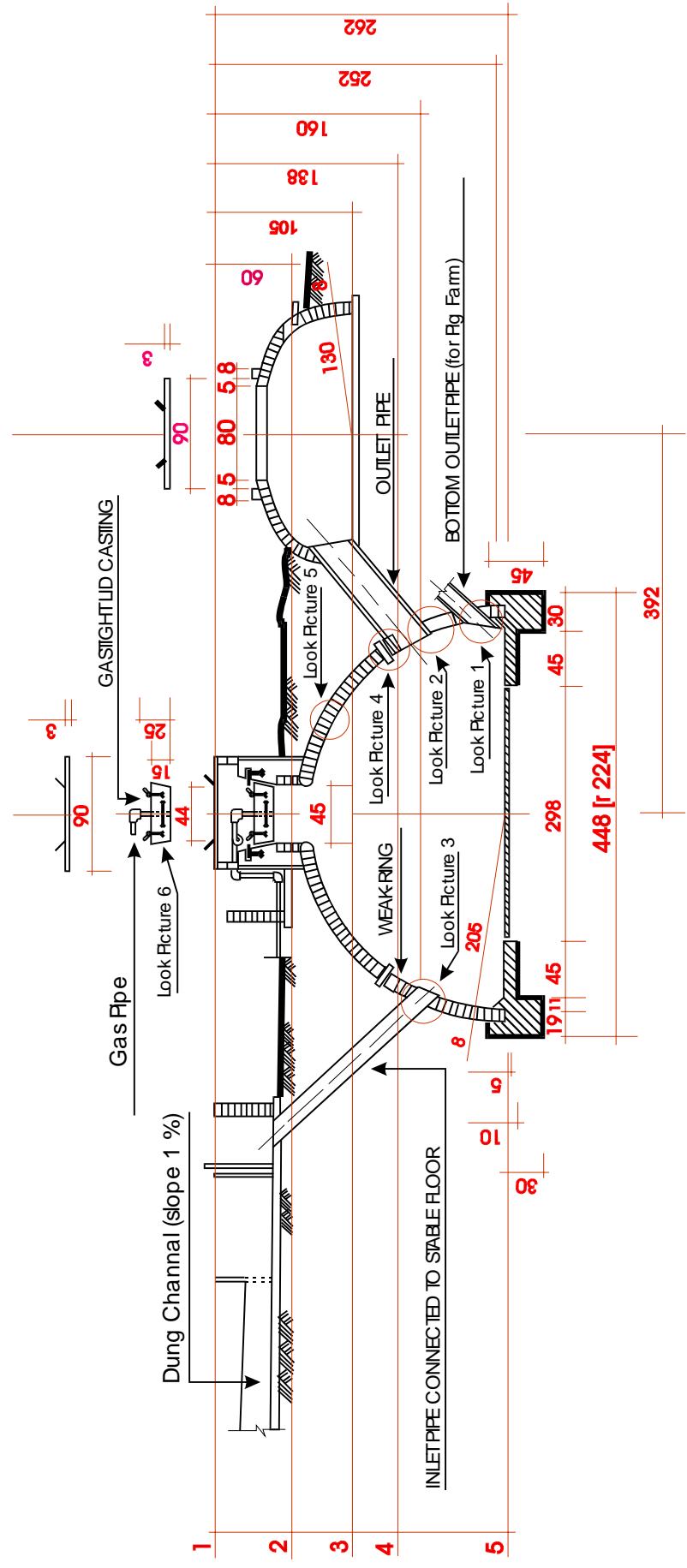



Expantion 1

Lower outlet Pipe Layer

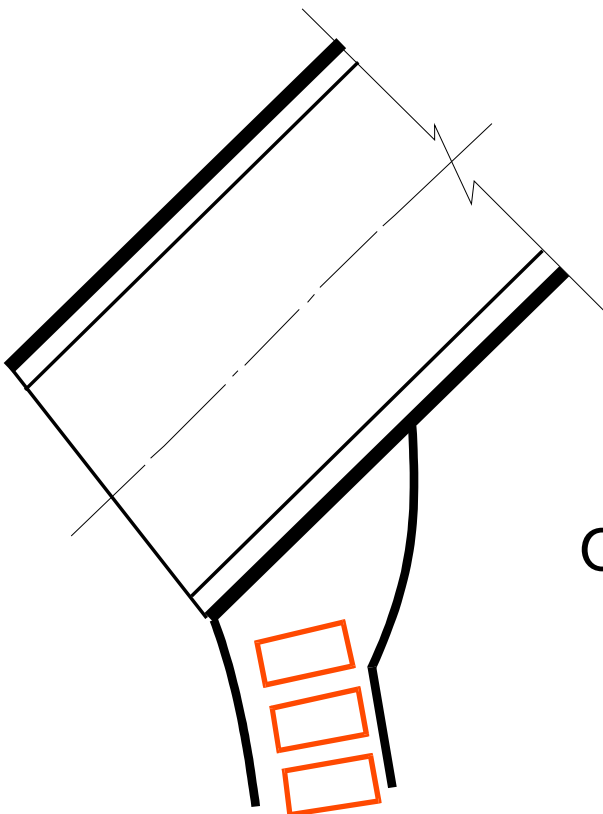
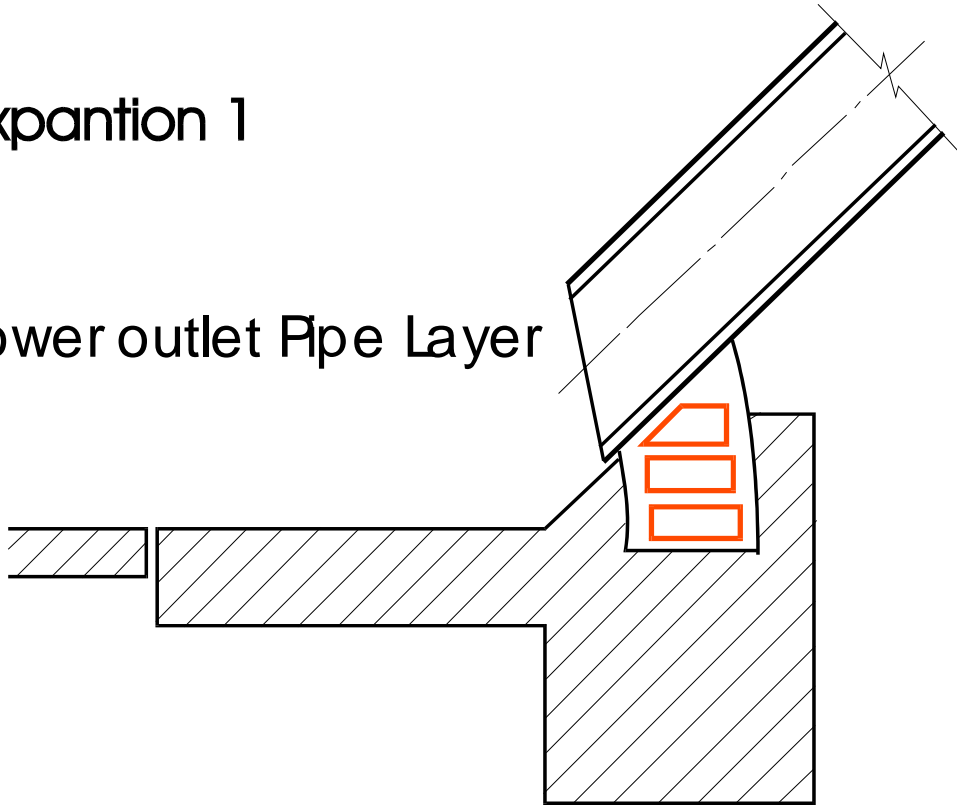

Expantion 2

Outlet Pipe Layer

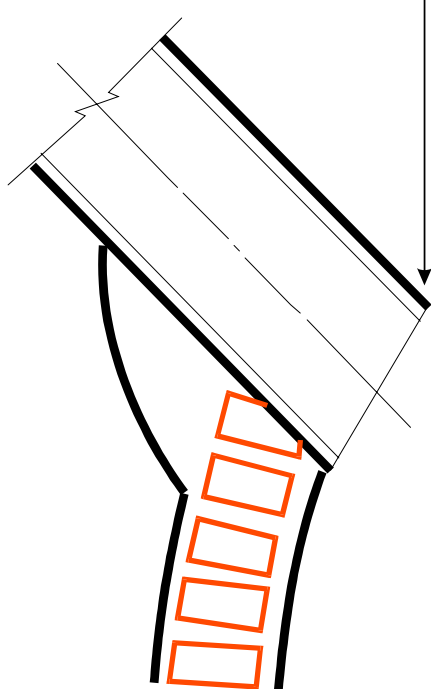

Expansion 3

Inlet Pipe Layer

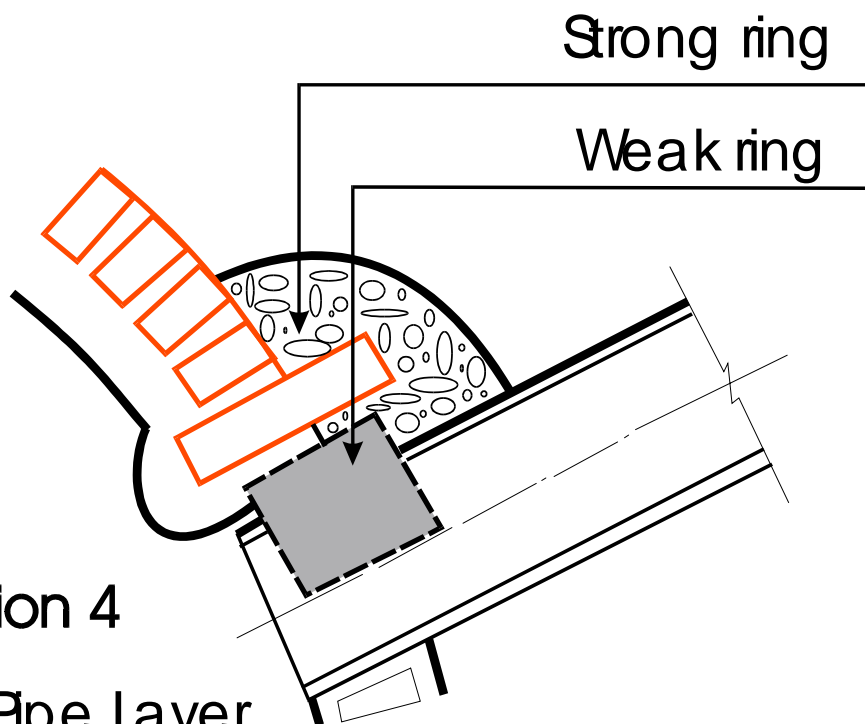
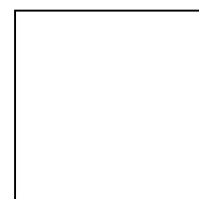

Strong ring

Weak ring

Expansion 4

Outlet Pipe Layer

Weak ring

Strong ring

# Expansion 5 Inside Plastering

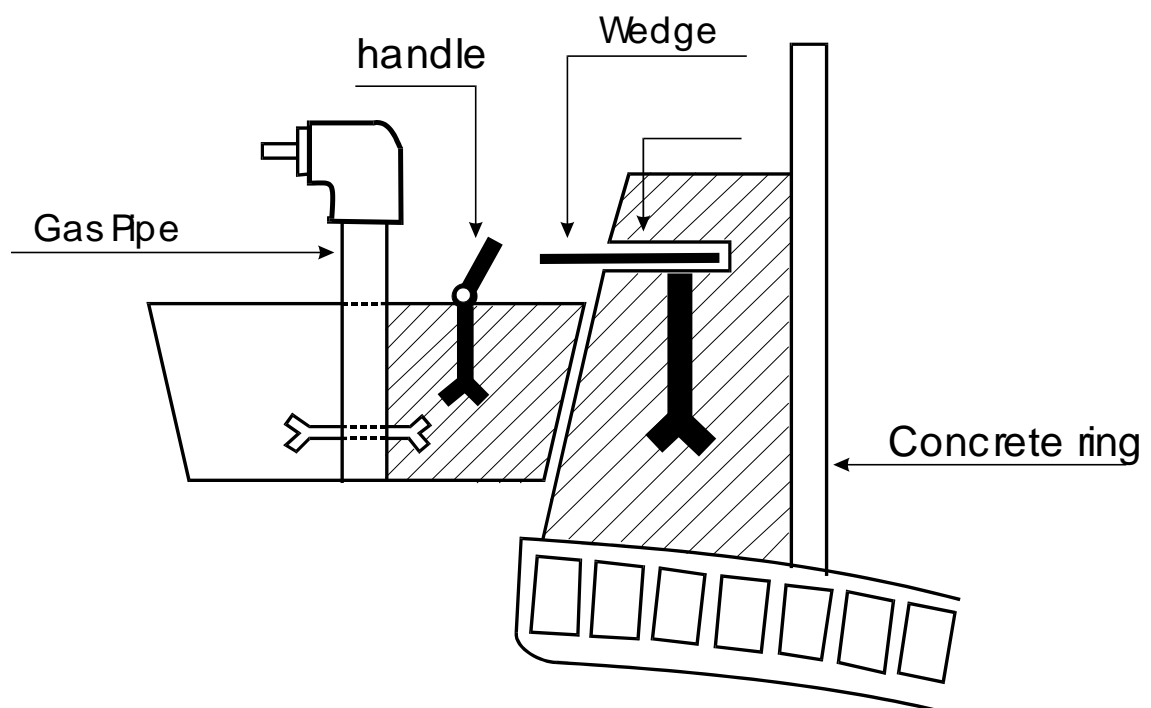
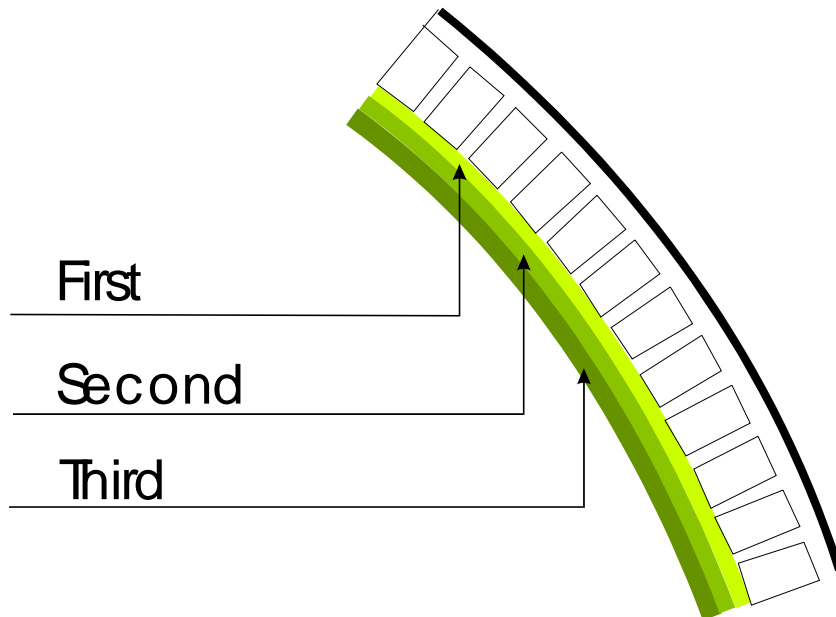

## CHAPTER 7

### Operation Manual of Bio-gas Reactor

#### 7.1 The Significance of the Bio-gas

Bio-gas is a form of energy produced when organic materials such as animal excrement or products that are left over from agriculture are fermented easily and at low cost. The advantage of bio-gas is that it replaces other energy sources for example charcoal, firewood, electricity, liquid petroleum gas and oil. After animal excrement had been fermented in the gas plant it becomes a good quality and odorless substrate, which is better than fresh manure in improving the soil for the agriculture. As an energy source, it prevents deforestation and animal excrement from causing pollution, smell, flies and water pollution in the community.

Nowadays the use of bio-gas has spread from small farms to big animal farms. It is expected that bio-gas will be a significant source of energy in the future to preserve the environment, solve the pollution problem and to promote better health to agriculture and community.

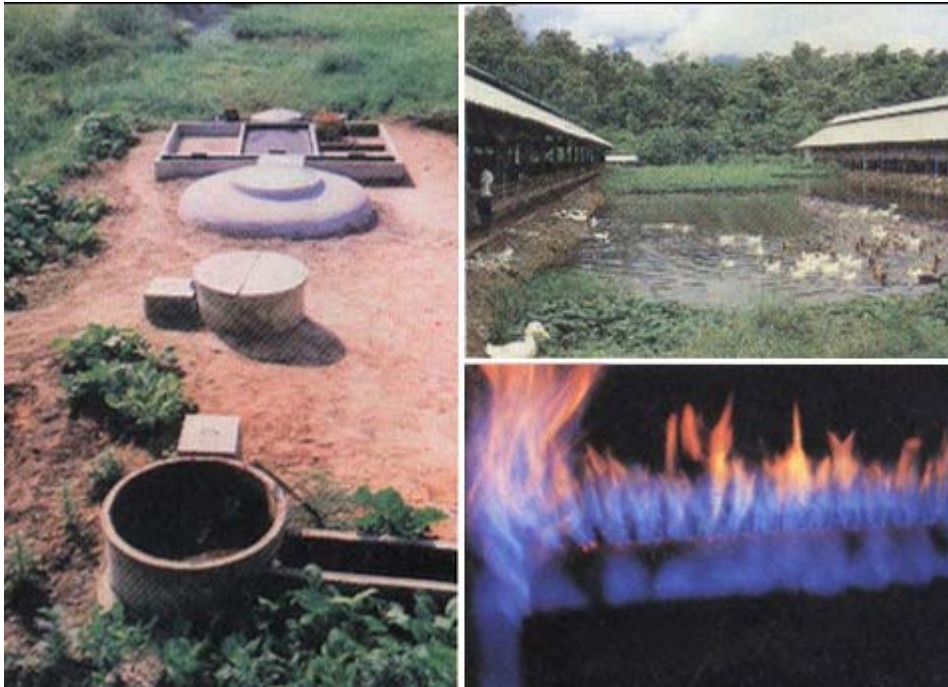

#### 7.2 Bio-gas Plant and Agriculture Cycle System

Three main cycle components as in full agriculture system are animal farming, bio-gas plant and animal products. Each provides direct economic benefit to agriculture.

*Provide energy to household uses*

*Provide organic fertilizer to improve the soil or for merchandise.*

### 7.3 Cycle System

1. Waste water and excrement from enclosure
2. Flow through the inlet pipe into mixing chamber
3. Then into digester chamber
4. Substrate overflow into expansion chamber
5. Into storage tank ready to be used in the agricultural fields or to be dried as fertilizer for merchandise.

### 7.4 Maintenance of Bio-gas System

Factors affecting bio-gas production

**7.4.1 Animal excrement:** daily quantity of excrement added must be sufficient, if too much or too little is added, very little or no gas will be produced as the bacteria dose not have sufficient time to break down the manure.

**7.4.2 Time:** suitable fermenting and breaking down time of manure is between 40-60 days.

**7.4.3 Mixing:** occasional stirring is required to help mixing the manure which will accumulate gas and prevent the forming of crust (cow dung) or scum (pig dung) in digester chamber.

**7.4.4 Chemicals:** such as antibiotic, pesticide, chemical fertilizer or other chemical products may damage bacteria that break down the organic materials in the chamber. The bacteria may stop working and gas will not be produced. Therefore chemical substances should not be released into bio-gas plants.

**7.4.5 Temperature:** the effective temperature for bacteria to grow is 37° C. If higher or lower than the suggested the bacteria will not develop, decreasing gas production. For example less gas will be produced in summer or winter.

**7.4.6 pH Balance:** A pH between 7-8.5 is optimal. If below the suggested pH, gas will not be produced.

## 7.5 Animal Excrement Adding

**First adding** (first 7 days) add cow or buffalo excrement daily.

- If cow or buffalo excrement is not available, pig excrement can be used at ratio of half the cow excrement suggested for a length of 2 weeks. After that add accordingly to the chart below.

Type of Materials	Sizes of Bio-gas plants						
	4.6M <sup>3</sup>	8M <sup>3</sup>	12M <sup>3</sup>	16M <sup>3</sup>	30M <sup>3</sup>	50M <sup>3</sup>	100 M <sup>3</sup>
Cow/buffalo excrement (litres)	300	600	800	1,200	2,200	3,600	7,200
Water (litres)	300	600	800	1,200	2,200	3,600	7,200

- After the plant is built and tested by filling with water, the water should be left inside. Open the valve to release the air until the mono-meter is at 0 and animal excrement can then be filled.
- The first adding of excrement should not be filled up to the top to avoid the slow production of gas or materials becoming decomposed. It should be separately added in small amount until fully filled.

**Next adding**, after 7 days of the first addition, add the materials regularly on daily basis as shown below:

Type of Materials	Sizes of Bio-gas plant						
	4.6M <sup>3</sup>	8M <sup>3</sup>	12M <sup>3</sup>	16M <sup>3</sup>	30m <sup>3</sup>	50m <sup>3</sup>	100M <sup>3</sup>
Cow/buffalo excrement (litres)	40	70	100	140	250	416	833
Water (litres)	40	70	100	140	250	416	833
Pig excrement (litres)	30	50	70	90	166	277	555
Water (litres)	60	100	140	180	332	555	1,110

- This addition will produce gas within 2-3 days.
- Release the gas from the tank 3 times before using it.
- Exceeded material will cease gas production.
- Use only fresh excrement, dry excrement is prohibited because it stops the process of producing gas and will block the pipes.

## 7.6 Animal Enclosure and Drainage Alley Maintenance



- ❑ Cleanliness of the enclosure is maintained daily by removing the excrement and putting it into the mixing chamber.



- ❑ Wash the enclosure with water and let it flow into drainage alley.
- \* Water that mixed with chemicals, antibiotics or antiseptics is not allowed to flow into the digester chamber as bacteria that activate the gas in the chamber will die.



## 7.7 Mixing Chamber Maintenance

- ❑ All rice hay, rice husk, gravel, soil, sand or non-organic materials must be removed from animal excrement when mixed with water, before releasing it into the mixing chamber. Those materials will shallow the level of the digester chamber and cause blockage in pipes.



- ❑ Mix or stir the mixture in the inlet pit until it becomes liquid, then open the gate of the mixing chamber to let the mixture flow into the digester chamber.



- ❑ Clean mixing chamber and gate at every addition of the excrement in the digester chamber.





- ❑ Use wooden stick to stir the fermented liquid once a week to avoid the formation of crust or scum at the bottom of the chamber or blockage of the inlet pipe.
- \* Before adding of excrement gas should be partly released for usage to let manure flow easily in to the digester chamber, as high pressure in the digester chamber would slow down the flow of the manure.

### 7.8 Digester Chamber and Outlet Pipe Maintenance

- ❑ Pour clean water into the inlet of the digester chamber to prevent the clay covering the pipe from drying and gas from leaking.



- ❑ Water level at the top of the inlet cover should not be over the steel clamp which tightens the gas pipe. It can become rusty.





- ❑ The inlet should be covered to prevent domestic animals from drinking this water and also prevent the water from evaporating quickly.



- ❑ The cover of the inlet pipe should be opened for maintenance once a year. The crust or scum formed by manure should be removed if possible.

*\*No excrement adding if gas is not produced for many days.*

### **7.9 Pig Excrement Chamber (Outlet Pipe Installed)**

Pig excrement forms more residue than cow or buffalo excrement and the removal residue from the floor base is more difficult. To prevent the blockage or the build up of residue on the floor, these instructions should be followed.

- Pull gate at the outlet pipe while the pressure is at the highest level, gas will help push out residue at the bottom.

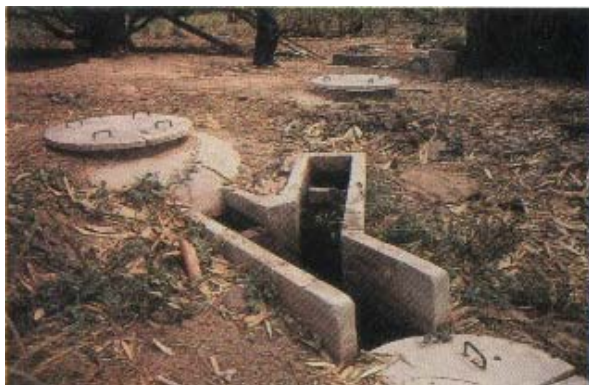

Leave gate opened for a while and after one smells the gas or the overflow slurry is very liquid then close the gate.

- \* The substrate should be removed at least once a week. If the substrate does not flow out when the gate is pulled, use wooden stick to unclog the outlet pipe.
- \* Gate must be closed tightly. If there is water leaking, the pressure in the digester chamber will decrease.
- \* When the storage tank is full, the gas must be removed for usage.

## 7.10 Expansion Chamber Maintenance

- ❑ Keep the outlet pipe free from blockage by clearing the dry manure or residue around the edge of the outlet pipe to let the manure flow freely.



- ❑ Close the lid of the expansion chamber to prevent animals or rainwater to fall in.

- ❑ At least once a week the inside of the chamber should be pushed and stirred with wooden stick to prevent crust or scum formed to block the pipe and the residue from forming at the bottom floor.



## 7.11 Storage Tank and Sand Bed Filter Maintenance





- ❑ Do not leave the substrate overflow from storage tank as it is unsightly and dirty.

- ❑ The substrate should be removed from storage tank and sand bed filter regularly to prevent the over filling and the flow of substrate back into the digester chamber. Use the substrate in the agricultural fields or store it for merchandise.



- ❑ Substrate in the storage tank can be used as liquid slurry form or mixed with cutting weeds as fermented fertilizer or dried for usage or as dried fertilizer for sale.

## 7.12 Water Trap Maintenance

- ❑ Water trap should be opened every two weeks without opening the valve at the inlet of the chamber to let the risen water flow out. Close the trap tightly to avoid the water from stopping the flow of gas.



- ❑ Water trap pit should be covered to avoid trash, leaves and rain which will cause problem or rust at the valve.

- ❑ Valve has to be changed or repaired immediately if there is any damage.



### 7.13 Gas Pipe Maintenance



- ❑ Gas pipe should be installed against the wall or post and secure tightly. The pipe will be broken easily if installed independently or loosely.

- ❑ Underground gas pipe should be covered safely to prevent the damage caused by animals, humans or vehicles.

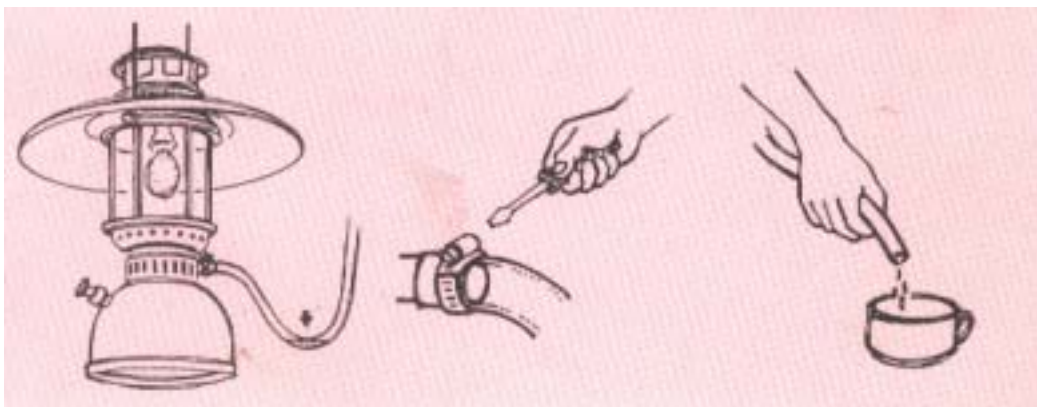

- ❑ Rubber hose should be checked every month for any water. Valve should be closed and hose emptied if there is water trapped inside. Hose clamp must be tightened after replacing the hose.

### 7.14 Manometer

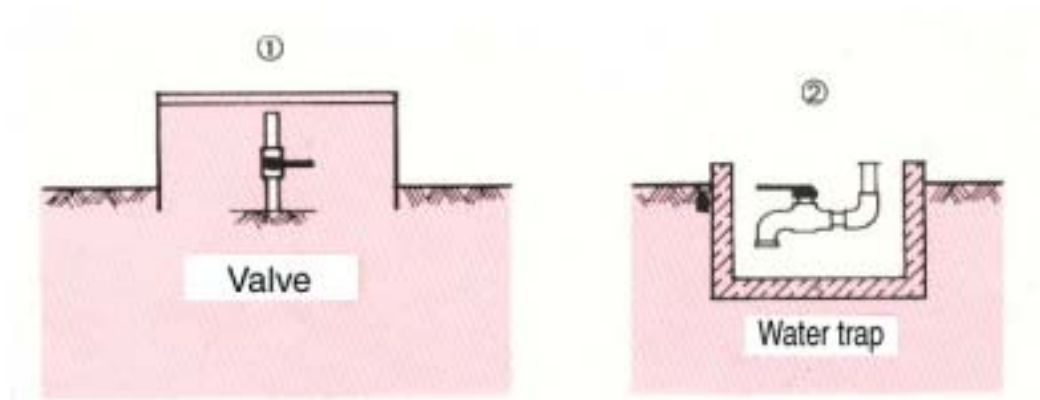

- Manometer is an important instrument in bio-gas system. It indicates any malfunction in bio-gas system.

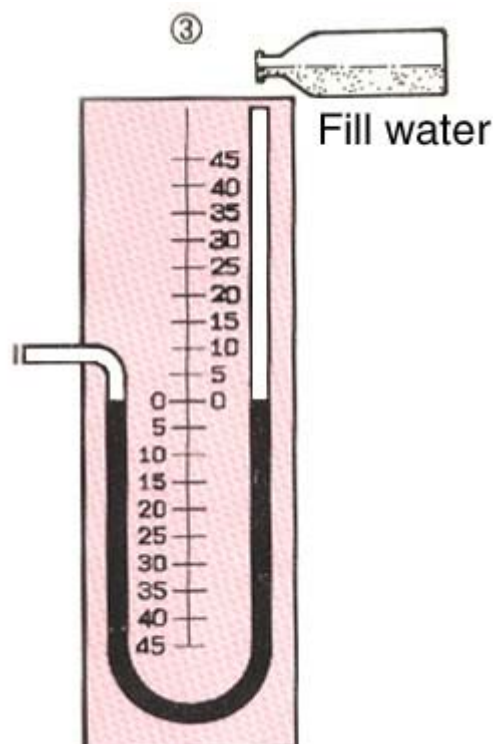

- Both water levels in mono-meter should be the same (when gas is emptied). To calculate the exact quantity of gas stored, adjust the level as follows :
  1. Close the valve at the inlet of digester chamber.
  2. Open valve at water trap
  3. Fill water at the end of the pipe until both levels are at 0.



## 7.15 Bio-gas Equipment Maintenance

- ❑ Valve must be closed for safety before cleaning any gas equipment.

### 7.15.1 Burner



- ❑ Always clean the burner by removing the head burner and pushing through the holes with a sharp wooden stick, wire or nail so that gas will flow out easily. Use a wire brush to get rid of sediment. Later scrub the rust or dirtiness out.



- ❑ For a stove with built-in cooking vessel built into the stove, remove the tray under the stove to clean.



- ❑ When stove is being used, open valve in the kitchen first and set fire prepared at burner then turn on the switch of stove last.

- ❑ Flame should come out from each hole of the burner head evenly, pale blue flame indicates clean burner but red flame indicates presence of sediment.
- ❑ After using stove, valve must be closed and switch on the stove must be turned off. If only valve is closed it may cause rust on the switch. Grease the switch occasionally, and do not let it dry. Change a new switch when damaged as stove has been long used.

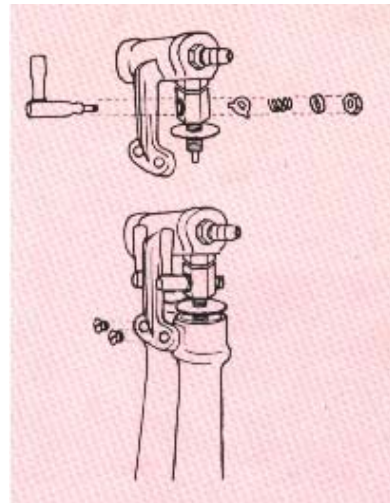

### 7.15.2 Lamp



- ❑ To clean or change gauze mantle, detach gas hose, remove the shade and head of the lamp first. After cleaning put them back together and screw tightly. Attach the hose back to the joint and secure with clamp.



To get rid of sediment, dismantle the lamp and wash parts with sediment in water. When it will come out then dry it quickly.

- ❑ To clean lamp shade and glass cover, wash with water and dry with clean cloth. At the same time, remove dirt and dead insects from the head of the lamp. Change new gauze mantle if broken and secure tightly.



- ❑ Lamp should be lit by candle because match is too short and may cause damage.



- ❑ When the brightness is low and the gauze mantle is flaming, adjust the nozzle to the left with tongs or up and down until the light is bright again.



### 7.15.3 Piglet Heater



- ❑ To light piglet heater, open valve and press auto switch and hold it. Set fire at the heater plate and wait until the plate is heated thoroughly and become red then release the switch.



- ❑ To clean, leave the head of the heater in water for 2-3 minutes then dry with cloth or leave in the sun.

- ❑ Air filter should be looked after and cleaned with soft brush to avoid dust or insects.



### 7.15.4 Engine

Stationary engines such as water pump, milling machinery, generator, animal feed mixer and milking machine can use bio-gas by installing gas pipes to the intake pipe of the engines.

For using bio-gas in engine, one main valve must be installed to PVC gas pipe and one small valve to rubber hose before connecting to the engine.

### 7.15.5 Gasoline Engine

- ❑ Start the engine with gasoline as normal then adjust the accelerator at moderate speed. Turn gasoline valve to fully close position then turn main valve to fully open position. Slightly open small valve, adjust and listen. Proper position is when the engine runs smoothly without misfiring.



*\* Let gasoline flow to replace gas (close gas valve) and leave engine run for another 3 minutes then turn the engine off.*

### 7.15.6 Diesel Engine

- ❑ Start the engine and adjust accelerator at moderate position. Slightly open diesel fuel valve and at the same time turn main valve to fully open position then open the small valve to the position which the engine runs smoothly.



*\* Turn the engine and main valve off when not in use.*

- ❑ If higher RPM (accelerating) is required, small valve must be adjusted to let more gas enter. Engine will be accelerated without adjusting the accelerator.
- ❑ At the first installation after accelerator is properly adjusted, remove handle from the small valve for safety reason.
- ❑ The next starting  
*Benzene engine* is started by gasoline. When engine is started, gasoline valve must be closed and open the main valve to fully open position.  
*Diesel engine* will run normally after starting the engine and opening the main valve.



### 7.16 Practice Rules and Caution in Bio-gas Uses

- ❑ In a new chamber, gas produced after animal excrement has been first added must be vented as it cannot be used. It should be vented 2-3 times or until gas becomes flammable.

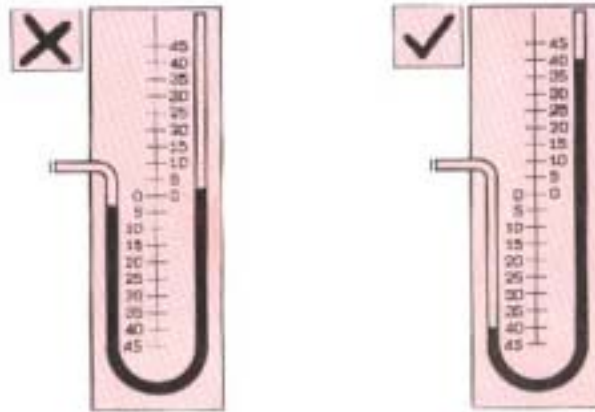

- ❑ Use manometer to check magnitude before using gas. Pressure should be at 10-80 cm.
- ❑ Do not leave valve opened when not in use. If pipe or hose is damaged, gas may leak and cause a fire.
- ❑ Light should be lit closely at the head of burner before opening the valve. If the valve is opened first, gas may come out exceedingly and is dangerous.
- ❑ Do not use igniter to lighten the stove because bio-gas is a slowly flammable passive gas.



- ❑ When valve is left open, excess gas will result in a bad smell. Close valve immediately and open windows and doors for ventilation. Do not fire until there is no more gas leaking.

#### 7.16.1 Gas Saving

### 7.16.1 Gas Saving

- ❑ Food ingredients and condiments must be prepared before starting stove.



- ❑ Cooking container should be placed 1 inch above the head of the stove to save gas and avoid loss of heat energy while cooking.

Lid should be used regularly to cover cooking container when boiling, steaming or decocting to save energy and time for cooking.



- \* Stove should not be placed in windy area as the wind will blow the heat away.
- \* Stir frying should be in high heat while boiling or deep frying should be in medium heat.

daily will be changed and the component in this substrate can be used in agriculture as a better fertilizer than unfermented manure (unfermented fertilizer).

## 7.18 Methods of Using Substrate from Expansion Chamber

### 7.18.1 Liquid slurry

#### *1. Draining through drainage alley*

Substrate from expansion chamber will flow easily through the alley or drainage pipe with the aid of gravity if the ground is on slope area and bio-gas plant is located at higher elevation than agriculture areas. The loss of nutrients will be lower.



#### *2. Using pump*

Pump could be used in flat or remote area to pump substrate out directly from storage tank (which is filtered through sand bed) and sent along the alley or pipe to agriculture areas. (Density of substrate from expansion chamber is one of the limitation of using pump in remote area.)



#### *3. Using container*

Special implement is required to shift substrate from expansion chamber to remote area. Wheel barrows or carts are suitable for short distance. While animals or engines powered vehicles are very helpful for long distances.



## 7.19 Dry Manure

### 1. *Fermented fertilizer*

Substrate from expansion chamber can be kept in form of fertilizer when fermented together with cut weeds or grass. It is one of the easy ways of shifting. Scoop manure from expansion chamber and pour alternately over layers of cut grass. Stack of fermented grass should be turned over several times to speed up the process. Pile of fertilizer should be near the storage tank for easy access.



### 2. *Filtered in sand bed*

Filter component is gravel, coarse sand and fine sand. Water that has been filtered will flow into a pit to settle down, substrate will be left on top of sand bed surface. It will dry and be ready for removed within 3-4 days.



### 3. *Drying technique*

This technique is recommended when moving substrate from expansion chamber to remote area. Location for drying should be near the bio-gas plant. The ground should be a water proof concrete slab to avoid the liquid from seeping into ground water.

Farmers who do not use the substrate from expansion chamber in their field or there is a lack of implementation to help in shifting should use dry technique. Shifting dry manure is more practical than using slurry. Besides, dry manure can be packed and sold in small bags, sacks, bamboo baskets or loaded on to trucks.





### 7.20 Problems and Solutions

	Problems	Solutions
1. Pressure is low or decreasing even gas is not used	<ul style="list-style-type: none"> <li>✱ Too little excrement adding when there is no consumption</li> <li>✱ Lid of digester chamber is leaking</li>   <li>✱ Gas pipe or valve is leaking</li>   <li>✱ Blockage at the end of gas pipe of digester chamber inlet</li>   <li>✱ Fixed dome is cracked</li> </ul>	<ul style="list-style-type: none"> <li>➤ Add more excrement as related to size of chamber</li>   <li>➤ Check for any bubbles on the surface of trap water. If there is any leak, open the lid and have clay changed then close the lid.</li> <li>➤ Use bubbles from soap liquid to check for leakage of valves and joints including all instruments involved with gas, pipes and hoses also check that water trap and/or gate of outlet pipe (pig chamber) is tightly closed.</li> <li>➤ Disconnect hose between joint of digester chamber inlet and gas pipe. Have them checked by using thin stick or soft wire to unclog any manure that may cause blockage.</li> <li>➤ Dig soil around the outside dome and check for leakage by using soap water.</li> <li>➤ Bubbles will indicate the leak. Pump or take out all manure until the chamber is empty. Clean the chamber and check for any crack inside fixed dome. Chip cement around the crack and fill it up with new cement, added with waterproofer.</li> </ul>
2. Pressure is normal but gas supply runs out quickly.	<ul style="list-style-type: none"> <li>✱ Scum on surface of digester chamber</li> <li>✱ Residue sinks to bottom / shallow level</li> <li>✱ Scum on surface of expansion chamber</li> <li>✱ Outlet pipe is blocked</li> </ul>	<ul style="list-style-type: none"> <li>➤ Open lid and add water. Use wooden stick to stir until scum is dissolved then close the lid.</li> <li>➤ Pull gate of the outlet pipe (pig chamber) up to release residue out.</li>   <li>➤ Use stick to break scum then scoop out.</li>   <li>➤ Use stick to unclog the pipe</li> </ul>
3. Pressure is too high	<ul style="list-style-type: none"> <li>✱ Gas pipe is blocked</li> <li>✱ The inlet of expansion chamber is on high level</li> </ul>	<ul style="list-style-type: none"> <li>➤ Use stick to unclog the pipe</li> </ul>
4. Bubbles at the entrance of the expansion chamber	<ul style="list-style-type: none"> <li>✱ Add too much excrement</li> </ul>	<ul style="list-style-type: none"> <li>➤ Stop adding excrement for 7 days or add lime 5 bags a day for 4 days.</li> </ul>

5. Gas pressure is not consistent	<ul style="list-style-type: none"> <li>✱ Water is trapped in gas pipe</li> </ul>	<ul style="list-style-type: none"> <li>➤ Open water trap valve to empty water in the pipe then close valve tightly.</li> </ul> <p>Solutions</p>
6. Enough pressure but gas have bad smell and is nonflammable	<ul style="list-style-type: none"> <li>✱ pH factor is too low indicates too much acid</li> <li>✱ Add too much excrement</li> <li>✱ Antiseptic or other toxin is mixing in animal excrement</li> <li>✱ First filling with pig excrement</li> </ul>	<ul style="list-style-type: none"> <li>➤ Add lime into gas plant to decrease acid.</li> <li>➤ Stop adding excrement temporary (follow No 4)</li> <li>➤ Stop adding excrement 2-3 days, if the gas is still non flammable, remove old excrement and start new filling again</li> <li>➤ Leave the gas valve on until gas is flammable or remove old manure and replace with cow or animal manure from operating gas plant</li> </ul>
7. Enough pressure but gas is odorless and non flammable	<ul style="list-style-type: none"> <li>✱ Too much air</li> </ul>	<ul style="list-style-type: none"> <li>➤ Adjust air adjustment ring</li> </ul>
8. Uneven flame	<ul style="list-style-type: none"> <li>✱ water is trapped in gas pipes or hoses</li> </ul>	<ul style="list-style-type: none"> <li>➤ Open water trap valve to empty the water and close tightly</li> </ul>
9. Low flame	<ul style="list-style-type: none"> <li>✱ Low gas pressure</li> <li>✱ Nozzle hole is too small or head burner is blocked</li> </ul>	<ul style="list-style-type: none"> <li>➤ Check gas plant and gas pipe for leakage.</li> <li>➤ Enlarge nozzle hole to diameter as follows</li> <li>➤ <i>Cooking burner</i></li> <li>➤ Size of inner ring nozzle 1.2mm (3/64")</li> <li>➤ Outer ring 1.6mm (1/16")</li> <li>➤ <i>Double ringed burner</i></li> <li>➤ Size of inner ring nozzle 1.6mm (1/16")</li> <li>➤ Outer ring 2.3mm (3/32")</li> </ul>
10. High flame	<ul style="list-style-type: none"> <li>✱ Nozzle hole is too big</li> </ul>	<ul style="list-style-type: none"> <li>➤ Change nozzle to diameter as No.9</li> <li>➤ Control quantity of gas by adjusting the valve</li> </ul>
11. Yellow flame instead of pale blue flame.	<ul style="list-style-type: none"> <li>✱ Nozzle hole is too wide</li> </ul>	<ul style="list-style-type: none"> <li>➤ Open air regulator until flame is pale blue</li> </ul>
12. Flame return to switch instead of going up through burning holes	<ul style="list-style-type: none"> <li>✱ Gas return because head burner is blocked.</li> <li>Air inlet is not completely closed</li> </ul>	<ul style="list-style-type: none"> <li>➤ Clean burner using wire or nail unclog burning holes or use wire brush to scrub and remove sediment and dirt from burner.</li> <li>➤ As for cooking stove adjust ring of air regulator at fully close position</li> </ul>

## **Bibliography**

1. Asian Productivity Organization (2000) *Green Productivity Training Manual*
2. Vietnam Productivity Center (2000) *Report on Green Productivity Demonstration Project in Community Development*
3. World Health Organization (1976) *Management of Solid Wastes in Developing Countries*
4. Tchobanoglous, Theisen, Vigil (1993) *Integrated Solid Wastes Management* McGraw-Hill International Editions
5. Ram Bux Singh (1974) *Bio-gas Plant: Generating Methane from Organic Wastes* Mamta Press India
6. Elizabeth C. Price & Paul N. Cheremisinoff (1981) *BIOGAS: Production & Utilization* Ann Arbor Science
7. United Nations (1984) *Updated Guidebook on Biogas Development*
8. K.C. Khandelwal & S.S. Mahdi (1986) *Biogas Technology a Practical Handbook Volume 1* Tata McGraw-Hill Publishing Co. Ltd.
9. Klaus von Mitzlaff (1988) *Engines for Biogas, Theory, Modification, Economic Operation* GTZ GmbH, Eschborn